



## AVK GATE VALVE, FLANGED, BS STD, PN10/16

21/36-002

Ductile iron, EN 1092 flange, A2 bolts, stemcap, EPDM wedge rubber, GSK coating

The AVK series 21 are flanged, resilient seat gate valves with replaceable stem seal designed to the heavy duty BS5163 Type B standard for use in systems with drinking water, waste water or other neutral liquids.

### Product description:

Resilient seat gate valve for water and waste water. Temperature range: -10° C to +70° C. 10% solid matter.

### Standards:

- Designed according to BS5163 Type B, Designed according to EN 1074 part 1 & 2
- Face-to-face dimension according to EN 558 Table 2 Basic Series 3
- Flange drilling to EN1092, PN10/16

### Test/Approvals:

- Hydraulic test according to 1.5 x PN
- Materials approved according to WRAS

### Features:

- Cap top as standard
- Fixed, integral wedge nut prevents vibration and ensures durability
- Stem seal replaceable under pressure
- The ductile iron core is fully vulcanized with drinking water approved EPDM rubber, no iron parts are exposed to the medium and the excellent rubber vulcanization prevents creeping corrosion underneath the rubber
- The wedge has a large through bore and as there are no hollows in the core, stagnant water or impurities cannot collect and cause contamination
- Stainless steel stem with rolled threads for high strength
- Full circle brass thrust collar provides fixation of the stem and low free running torques
- Double stem seal: a replaceable polyamide bearing with two O-rings and an O-ring on the stem
- Round bonnet gasket fixed in a recess groove in bonnet preventing it from being blown out by pressure surges
- Bonnet bolts encircled by the bonnet gasket to protect against contact with the fluid and against corrosion
- Fusion bonded epoxy coating acc. to GSK, blue RAL 5017
- Bonnet and gland bolts sealed with hot-melt for protection against corrosion

### Accessories:

Hand wheel, extension spindle, full range of flange adaptors and dismantling joints



Expect ... **AVR**

The designs, materials and specifications shown are subject to change without notice due to the continuous development of our product range.

# AVK GATE VALVE, FLANGED, BS STD, PN10/16

21/36-002

Ductile iron, EN 1092 flange, A2 bolts, stemcap, EPDM wedge rubber, GSK coating

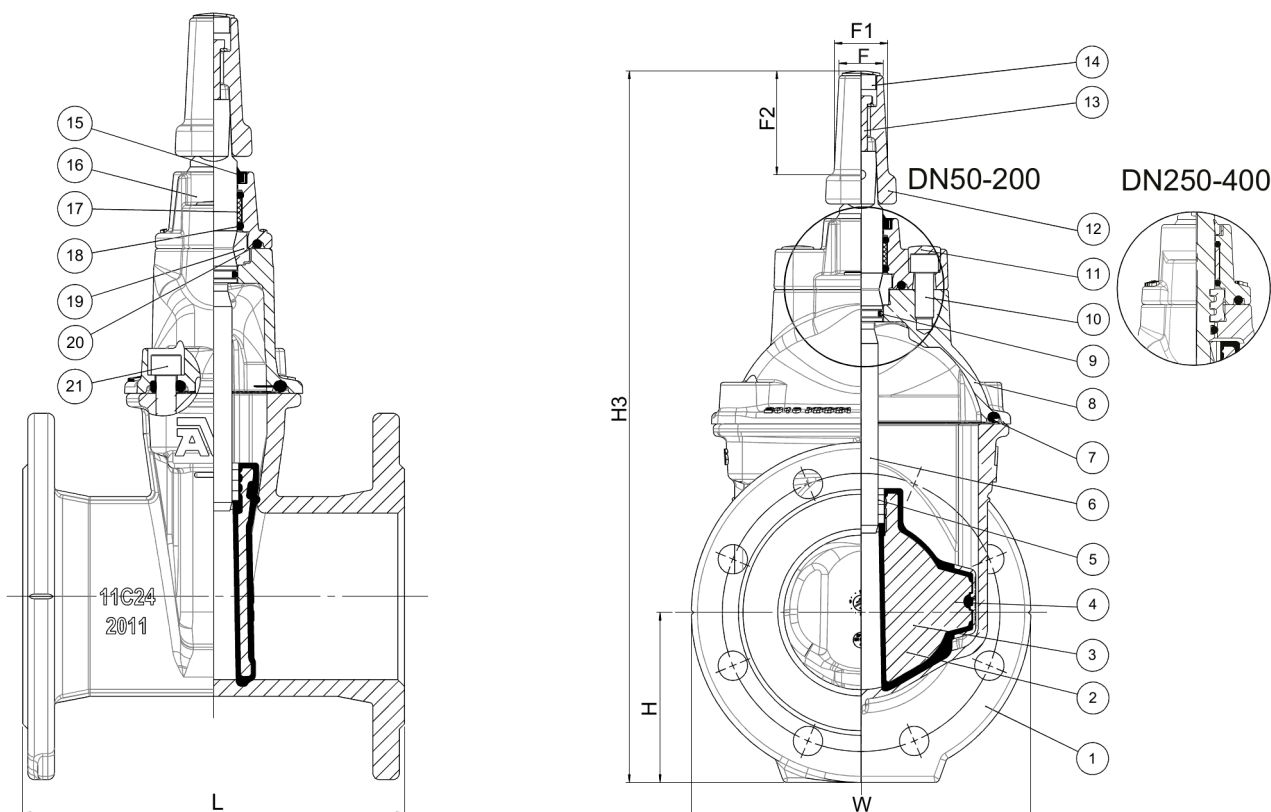

## Component list:

1. Body	Ductile iron GJS-500-7	12. Stem cap	Grey iron
2. Wedge rubber	EPDM rubber	13. Screw	Stainless steel A2
3. Wedge core	Ductile iron GJS-500-7	14. Insert	Plastic
4. Wedge shoe	Polyamide	15. Wiper ring	NBR rubber
5. Wedge nut	Brass	16. Gland flange	Ductile iron GJS-500-7
6. Stem	Stainless steel 1.4021 (420)	17. Bearing shell	Polyamide
7. Bonnet gasket	EPDM rubber	18. O-ring	EPDM rubber
8. Bonnet	Ductile iron GJS-500-7	19. Thrust collar	Brass
9. O-ring	EPDM rubber	20. O-ring	EPDM rubber
10. Bolt	Stainless steel A2	21. Bolt	Stainless steel A2
11. Cover	Hot melt glue		

Components may be substituted with equivalent or higher class materials without prior notification.

## Reference nos. and dimensions:

AVK ref. no.	DN mm	Flange drilling	L mm	W mm	H mm	H3 mm	F mm	F1 mm	F2 mm	Turns to open	Theoretical weight/kg
21-050-36-2142064	50	PN10/16	178	173	83	411	28	35	63	5	14
21-065-36-2142064	65	PN10/16	190	185	93	422	28	35	63	6	16
21-080-36-2142064	80	PN10/16	203	200	100	437	28	35	63	7.5	17
21-100-36-2142064	100	PN10/16	229	220	110	469	28	35	63	8.5	19
21-150-36-2142064	150	PN10/16	267	285	143	591	28	35	63	12.5	34
21-200-36-2042064	200	PN10	292	340	170	705	28	35	63	16.5	52
21-200-36-2142064	200	PN16	292	340	170	705	28	35	63	16.5	52
21-250-36-2042064	250	PN10	330	422	200	872	28	35	63	21	85
21-250-36-2142064	250	PN16	330	422	200	872	28	35	63	21	84
21-300-36-2042064	300	PN10	356	455	228	983	28	35	63	25	117
21-300-36-2142064	300	PN16	356	455	228	983	28	35	63	25	116
21-350-36-2042064	350	PN10	381	564	253	1186	40	48	75	29	179
21-350-36-2142064	350	PN16	381	564	267	1200	40	48	75	29	212

The designs, materials and specifications shown are subject to change without notice due to the continuous development of our product range.

**AVK GATE VALVE, FLANGED, BS STD, PN10/16****21/36-002****Ductile iron, EN 1092 flange, A2 bolts, stemcap, EPDM wedge rubber, GSK coating****Reference nos. and dimensions:**

AVK ref. no.	DN	Flange	L	W	H	H3	F	F1	F2	Turns	Theoretical
	mm	drilling	mm	mm	mm	mm	mm	mm	mm	to open	weight/kg
21-400-36-2042064	400	PN10	406	564	283	1243	40	48	75	33	189
21-400-36-2142064	400	PN16	406	564	290	1250	40	48	75	33	217