

KOSSAN

PE Water Tank

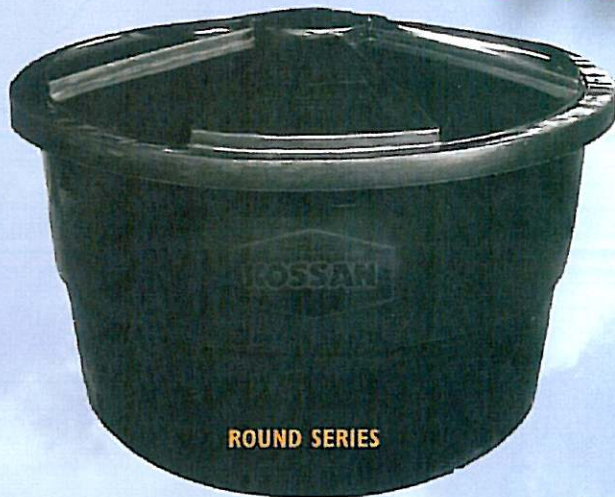

FEATURES & ADVANTAGES

- ☞ Non-toxic & odourless
- ☞ Zero maintenance & highly durable
- ☞ Seamless one-piece construction
- ☞ Stress-free and leak-proof
- ☞ Lightweight & strong
- ☞ Food grade material
- ☞ Made from superior grade Polyethylene resins
- ☞ Capacity range from 50-600 gallons

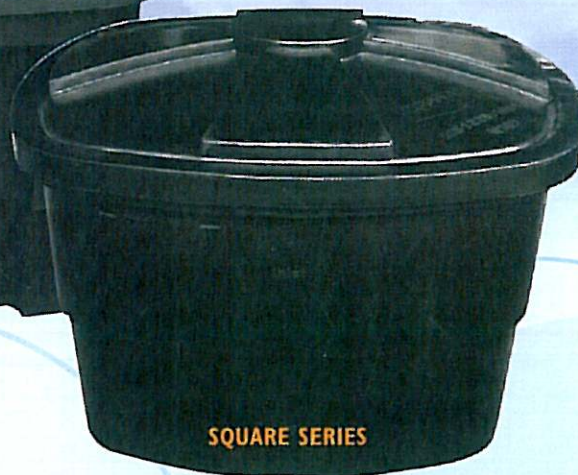

SPAN
Suruhanjaya Perkhidmatan Air Negara

MS
SIRIM
MS 1225 : PART 1:2007

Cert No : 21376



WARRANTY TERMS & CONDITIONS

1. Kossan PE Water Tank has a warranty period of 10 years for cold water storage for indoor use and 5 years outdoor use.
2. Warranty period is applicable on a prorated basis against manufacturer defects only, manufacturer will not be liable for any consequent losses, defects or damages as a result of improper use or incorrect installation.
3. Kossan FRP's liability is strictly limited to the replacement of water tank only.
4. Kossan PE Water Tank is to be used for storing cold water at a stationary position only.

ROUND SERIES										
MODEL	CAPACITY (Gallons)		EXTERNAL DIMENSIONS MM (Inches)							
	Effective	Nominal	Diameter (Top)		Diameter (Base)		Height w/o cover		Height c/w cover	
N50RAB	50	80	1050	42	862	34	510	20	590	24
N70RAB	70	100	1150	46	958	38	545	22	630	25
N100RAB	100	150	1270	50	1070	42	625	25	740	30
N150RAB	150	200	1420	56	1220	48	695	28	820	32
N200RAB	200	250	1575	62	1295	51	790	31	940	37
N250RAB	250	300	1550	61	1340	53	900	36	1040	41
N300RAB	300	400	1700	67	1445	57	890	35	1040	41
N400RAB	400	500	1680	66	1345	53	1275	51	1450	57
N500RAB	500	600	1750	69	1320	52	1475	58	1625	64
N50RA	50	80	1016	40	838	33	508	20	610	24
N70RA	70	100	1040	41	838	33	635	25	737	29
N100RA	100	150	1143	45	889	35	711	28	840	33
N150RA	150	200	1346	53	1092	43	735	29	864	34
N150RAA	150	200	1500	59	1220	48	610	24	735	29
N200RA	200	250	1448	57	1168	47	787	31	910	36
N200RAA	200	250	1345	53	1115	44	910	36	1040	41
N250RA	250	300	1500	59	1220	48	910	36	1040	41
N250RAA	250	300	1420	56	1140	45	990	39	1115	44
N300RA	300	400	1473	58	1168	46	1220	48	1345	53
N300RAC	300	400	1240	49	990	39	1400	55	1550	61
N330RA	330	430	1600	63	1245	49	1195	47	1270	50
N350RA	350	450	1500	59	1220	48	1270	50	1420	56
N400RA	400	500	1728	68	1372	55	1195	47	1295	51
N500RA	500	600	1676	66	1270	50	1475	58	1650	65

SQUARE SERIES										
MODEL	CAPACITY (Gallons)		EXTERNAL DIMENSIONS MM (Inches)							
	Effective	Nominal	L & W (Top)		L & W (Base)		Height w/o cover		Height c/w cover	
N50SAB	50	80	991	39	838	33	508	20	584	23
N70SAB	70	100	1067	42	889	35	559	22	660	26
N100SAB	100	150	1168	46	914	36	660	26	762	30
N150SAB	150	200	1420	56	1220	48	700	28	820	32
N200SAB	200	250	1524	60	1194	47	711	28	840	33
N250SAB	250	300	1600	63	1355	53	865	34	1015	40
N300SB	300	400	1980	78	1676	66	660	26	790	31
N150SA	150	200	1397	55	1118	44	635	26	762	30
N250SA	250	300	1499	59	1170	46	889	35	1040	41
N300SA	300	400	1651	64	1295	51	965	38	1118	44

RECTANGULAR SERIES							
MODEL	CAPACITY (Gallons)		EXTERNAL DIMENSIONS MM (Inches)				
	Effective	Nominal	L & W (Top)	L & W (Base)	Height w/o cover	Height c/w cover	
KT-3	15	30	29 x 21	24 x 16	15	16	
KS-50	25	50	37 x 28	31 x 22	13	14	
KS-80	50	80	48 x 32	42 x 26	15	16	
KS-100	60	100	51 x 36	45 x 30	15	16	
KS-150	70	150	56 x 45	49 x 38	18	20	
KSL-150	70	150	68 x 41	62 x 35	16	17	
KS-170	70	150	66 x 55	61 x 49	15	16	
KSB-200	100	200	64 x 57	57 x 51	17	19	
KSS-200	100	200	61 x 60	55 x 53	17	19	
KSL-200	100	220	75 x 47	68 x 41	18	20	
KS-250	150	250	64 x 52	57 x 44	22	24	
KS-300	200	300	66 x 49	55 x 37	31	32	
KSL-300	200	300	80 x 50	72 x 43	21	23	
KS-350	200	350	72 x 62	63 x 53	22	23	
KS-400	200	350	63 x 51	53 x 40	30	34	
KSS-400	200	350	79 x 60	70 x 51	26	28	
KS-500	300	500	79 x 48	71 x 39	40	43	
KSA-150MH	70	150	69 x 31	62 x 24	18	20	
KSA-200MH	100	200	67 x 37	61 x 31	19	21	
KS-300MH	200	300	80 x 50	77 x 46	21	23	
KSA-400MH	200	350	90 x 83	84 x 77	14	16	

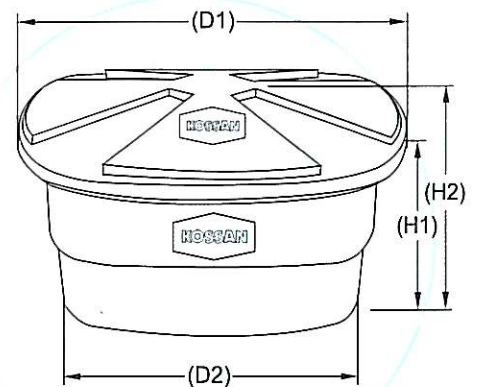

Remarks : -

1. All dimensions are rounded off to the nearest 10mm or 0.5 inch.
2. Kossan FRP Ind. (M) Sdn Bhd reserve the right to alter the specification without prior notice.
3. All capacity are rounded off to the nearest gallons.
4. Standard tank's sizes, colour is fixed but other dimension and color are available upon request.

KOSSAN FRP INDUSTRIES (M) SDN. BHD. (Co. No. 159277-H)

Lot 15853, Batu 5 3/4, Jalan Kapar, 42100 Klang,
Selangor Darul Ehsan, Malaysia.

Tel : 603-3291 7088, 3291 7077

Fax : 603-3291 9088 E-mail: marketing@kfrp2.com

Sole Distributor :

sanifix

sanifix m sdn bhd

徐水(馬)有限公司 (1-45567-3)

No 18 Jalan Telawi 5, Bangsar Baru,

59100 Kuala Lumpur, Malaysia.

T +603-2284 2322, 2284 2460

F +603-2284 9753, 2284 5422

E sani-fix@hotmail.com