



**MIG-MELEWAR**  
*Strong as S.T.E.E.L.*



CERTIFIED TO ISO 9001 : 2015  
CERT.NO.: AR0994

**PRODUCT  
CATALOGUE**



*Storage Bay, Factory 2*



*Galvanising Plant*



MIG-MELEWAR 2008



**MIG-MELEWAR**

[www.melewar-mig.com](http://www.melewar-mig.com)

**MELEWAR STEEL TUBE SDN. BHD. (111059-D)**

Lot 53 Persiaran Selangor, 40200 Shah Alam, Selangor Darul Ehsan, Malaysia

Tel : 603-5519 2455 (12 lines) Fax : 603-5519 2033 (Administration) 603-5510 6410, 603-55194017 (Sales Dept)

Email (Admin) : [enquiry@melewar-mig.com](mailto:enquiry@melewar-mig.com) (Sales) : [sales@melewar-mig.com](mailto:sales@melewar-mig.com)

GPS location: N03°04.276'E101°32.843'





# CONTENT

1	A Word about Steel Pipe
2 - 3	Company Profile & Premises and Plants of Melewar Steel Tube Sdn. Bhd.
4 - 5	Quality Recognition (ISO 9001:2015 & Product Certification)
6 - 7	Project References
8 - 9	Mill Processing Flow
10	Quality Products
11	Quick Search
12 - 13	Product Specification Table
14 - 15	Technical Details of BS EN 10255 / BS 1387 / MS 863. Welded Steel Pipes Type L2 (Light Series), Medium Series, Heavy Series and Type L1.
16	Welded Steel Pipes - Type L2 (Light Series)
17	Welded Steel Pipes - Medium Series (M)
18	Welded Steel Pipes - Heavy Series (H)
19	Welded Steel Pipes - Type L1
20 - 21	Welded Steel Pipes For General Purposes (Class AA – Manufacturer's Standard)
22	Carbon Steel Pipes for Ordinary Piping (JIS G3452)
23	Electric Welded Non-alloy Steel Tubes for Cement Lined Pipes (SPAN TS 21827:PART 2 / BS EN 10224)
24	British Standard Steel Tubes for Scaffolding (BS EN 39)
24	Carbon Steel Tubes for General Structural Purposes (JIS G3444)
25 - 26	AURORA Brand British Standard Galvanised Steel Conduit (BS 31 & BS 4568 & MS IEC 61386-1 / MS 61386-21)
27 - 28	Electric Resistance Welded Steel Pipe Piles (ASTM A252)
29 - 37	Square and Rectangular Hollow Sections (ASTM A-500)
38 - 53	Cold Formed Square, Rectangular and Circular Hollow Sections (BS EN 10219)
54 - 55	Carbon Steel Tube For Machine Structural Purpose (JIS G3445, Grade-STKM 11A)
56 - 57	Lipped Channels (JIS G3350)
58 - 59	Plain C-Channels (JIS G3350)
60 - 61	Special Sizes (Gate-Channel "B", U-Channel, Trolley Track, Door Rail Track, Oblong Tube & D - Tube)
62	Hot - Dip Galvanising Services (BS EN ISO 1461)
63 - 65	Conversion Table of Zinc Coating





## **A WORD ABOUT STEEL PIPE**

Pipes have played an important role in the advancement of civilization. It is recorded in history that clay pipes were first used in Babylon over 5,000 years ago. Copper tubes and lead pipes came after the clay pipes because these materials were comparatively easy to form into pipes. Following the invention of electrically welded steel pipes, thanks to modern science and technology, strong and durable welded steel pipes for a multitude of uses are available today. Besides its original function in the conveying of liquid and gas, pipes are also used as structural members in buildings, furniture, fence posts, lamp post, machinery and a host of other uses, all serving important phases of our daily lives.



# PREMISES AND PLANTS OF MELEWAR STEEL TUBE SDN. BHD.

## Headquarters

Lot 53, Persiaran Selangor,  
40200 Shah Alam,  
Selangor Darul Ehsan,  
Malaysia.



## Factory 1

Lot 53, Persiaran Selangor,  
40200 Shah Alam,  
Selangor Darul Ehsan,  
Malaysia.



## Factory 2

Lot 49, Jalan Utas 15/7,  
40200 Shah Alam,  
Selangor Darul Ehsan,  
Malaysia.



## Factory 3

Lot 10, Persiaran Selangor,  
40200 Shah Alam,  
Selangor Darul Ehsan,  
Malaysia.



## Factory 4

Lot 16, Jalan Pengapit 15/19,  
40200 Shah Alam,  
Selangor Darul Ehsan,  
Malaysia.





## COMPANY PROFILE

### CORE VALUES

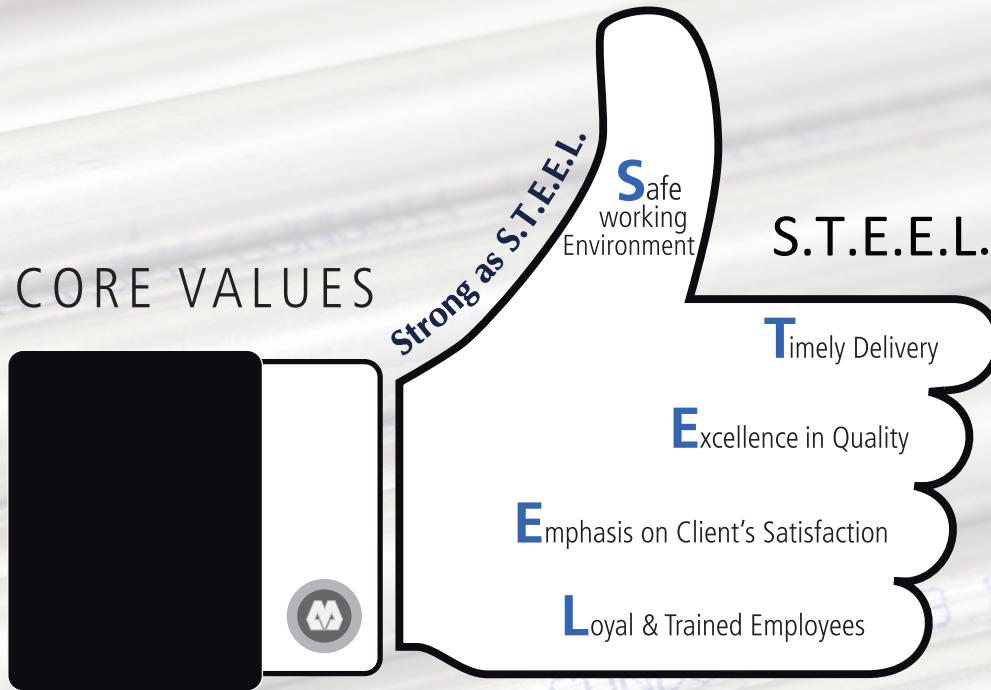

The year 1969 heralded the establishment of a Malaysian-Japanese joint venture into the steel pipe manufacturing industry with the establishment of Aurora Steel Tube Manufacturing Sdn Bhd. The company went into production with one production line in January 1970 at its factory in Jalan Gudang, Shah Alam.

To mark the participation of Maruichi Steel Tube Ltd, Osaka, Japan in 1972, a new name was adopted for the company - Maruichi Malaysia Steel Tube Sdn Bhd.

Within a matter of 2 years the company expanded its operations; a second factory equipped with additional production lines and hot dip galvanising facilities went into operation on a 7-acre site in Jalan Utas, Shah Alam in 1974.

In 1975 the company was converted into a public company.

The year 1982 saw the opening of the company's No. 3 factory at Persiaran Selangor, Shah Alam and the commencement of operation of

the company's 100% owned subsidiary, Tokyo Steel Wire Sdn Bhd, also in Shah Alam.

Maruichi Malaysia Steel Tube Berhad was listed on the Kuala Lumpur Stock Exchange in 1986. Our Corporate Headquarters was built at Persiaran Selangor in 1990. That same year also marked the commencement of operations of our wholly owned subsidiary, Cold Rolling Industry (Malaysia) Sdn Bhd, the first Cold Rolled Coil manufacturer in Malaysia.

Following a change in ownership, the company was renamed as Melewar Industrial Group Berhad (MIG) in November 2003. Product brand was then changed to MIG-MELEWAR.

At present, Melewar Steel Tube Sdn Bhd is the subsidiary of Mycron Steel Berhad. It has an installed capacity of more than 18,600m/tonnes per month with the ability to manufacture pipes from 10mm to 400mm O.D. MIG's products are widely used in the construction, furniture, automotive, bicycle and engineering industries. Today after more than three decades of experience in the steel pipe industry, the brand MIG-MELEWAR and AURORA CONDUIT spells quality, having made its name in the steel pipes industry where its products are highly acclaimed by both local as well as international users.



# QUALITY MANAGEMENT SYSTEM (QMS)

Melewar Steel Tube Sdn.Bhd strives to improve its operations and has always endeavoured to meet its customer's expectation. In 1997 MST achieved its ISO 9002 certification. Over the years, the effectiveness of the quality management system itself has been improved in order to adapt to the latest global challenges. In 2017, MST upgraded its Quality Management System to ISO 9001:2015 and this was accredited by SIRIM with IQNet certification.



SIRIM ISO 9001:2015



## PERAKUAN PEMATUHAN STANDARD (BAHAN BINAAN) FROM CIDB MALAYSIA

### IRON AND STEEL PRODUCTS

- Rigid Steel Conduit for Cable Management
- Steel Conduit for Electrical Wiring
- Steel Pipes for Water And Sewerage
- Welded Steel Pipes
- Welded Steel Tube



### IRON AND STEEL PRODUCTS

- Carbon Steel Pipes for Ordinary Piping
- Cold Formed Structural Steel Hollow Section



### IRON AND STEEL PRODUCTS

- Light Gauge Steel for General Purpose





# PRODUCT CERTIFICATION

Our quality products meet with the requirements of many international standards. Among them are as follows:



**British Standard**  
BS EN 10255:2004 for  
Welded Steel Tubes (Black &  
Galvanised)



**British Standard**  
BS 31:1940 for Steel Conduits  
for Electrical Wiring



**Japanese Standard**  
JIS G3452:2010 for Carbon  
Steel Pipes For Ordinary  
Piping (Black & Galvanised)



**Japanese Standard**  
JIS G3350:2009 for Light  
Gauge Steel for General  
Structural Class SSC 400



**Japanese Standard**  
JIS G3445:1988 for Carbon  
Steel Tube for Machine  
Structural Purposes Grade  
STKM 11A



**Japanese Standard**  
JIS G3444:2010 for Carbon  
Steel Tube for General  
Structure Grade STK400 &  
STK500



**American Standard**  
ASTM A500/A500M:2013  
for Cold Formed Welded  
Carbon Steel Structural  
Tubing In Round and Shape



**Malaysian Standard**  
MS IEC 61386-1 / MS  
61386-21 for Rigid  
Conduit System for Cable  
Management



**Malaysian Standard**  
MS 863:2010 for Welded  
Steel Pipes (Black &  
Galvanised)



**Malaysian Standard**  
SPAN TS 21827: Part 2:2013  
for Non-Alloy Steel Tube for  
Water and Sewerage



**EC Factory Production  
Control Certificate**  
EN 10219-1:2006 for Cold  
Formed Welded Structural  
Hollow Sections of Non-Alloy  
Steels



# PROJECT REFERENCES

## Supplying Quality Steel Pipes Across Malaysia





# PROJECT REFERENCES

## Supplying Quality Steel Pipes Across Malaysia



City One Mall



Civic Center



Kuching Center



Kuching Airport



Mydin Hypermarket



Spring Mall



UITM



UTC



Vivacity Megamall



Waterfront Mall

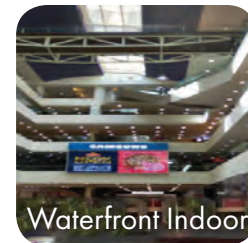

Waterfront Indoor

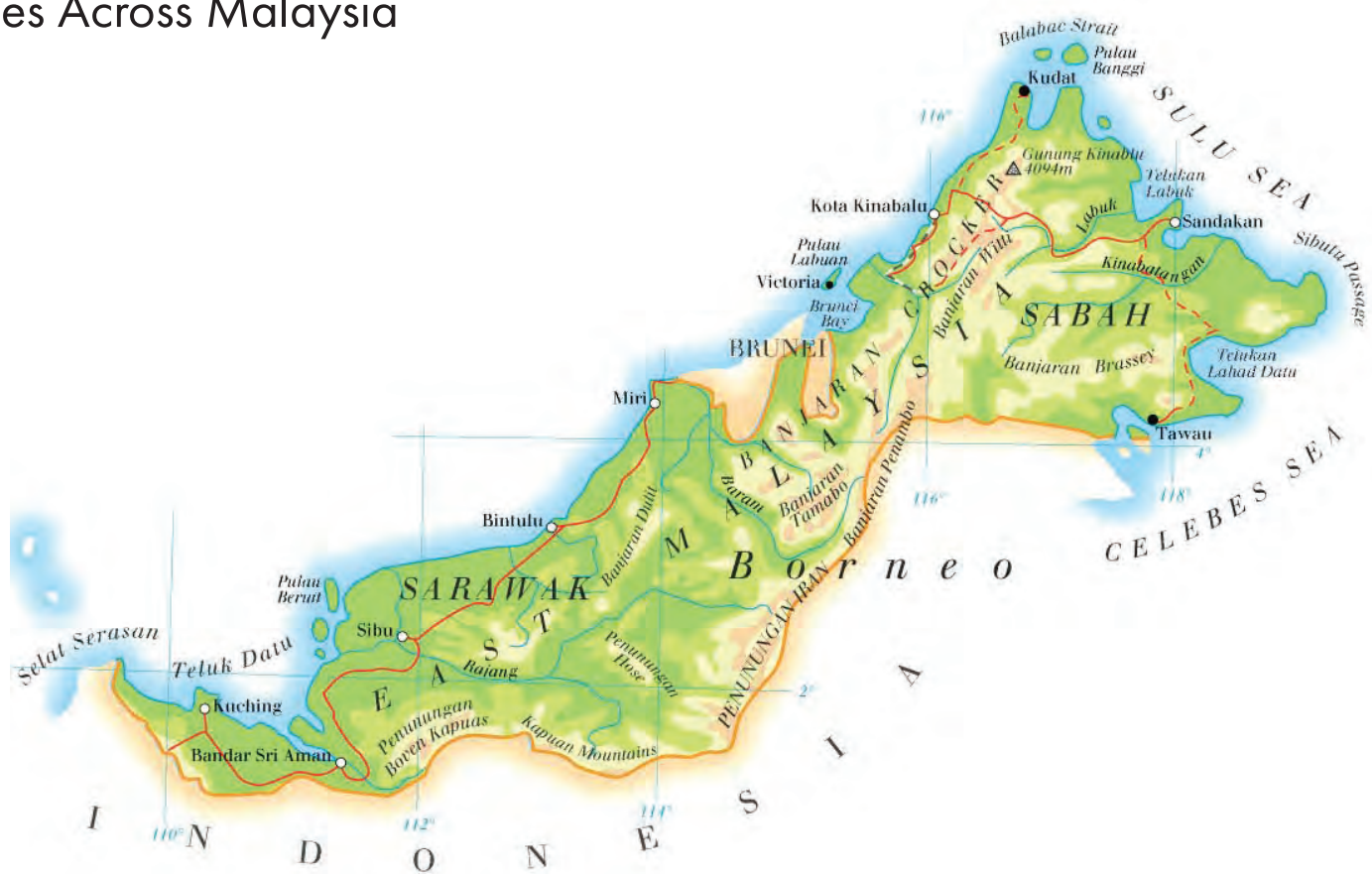



# MILL PROCESSING FLOW

## 1. Slitting Process



MOTHER COIL

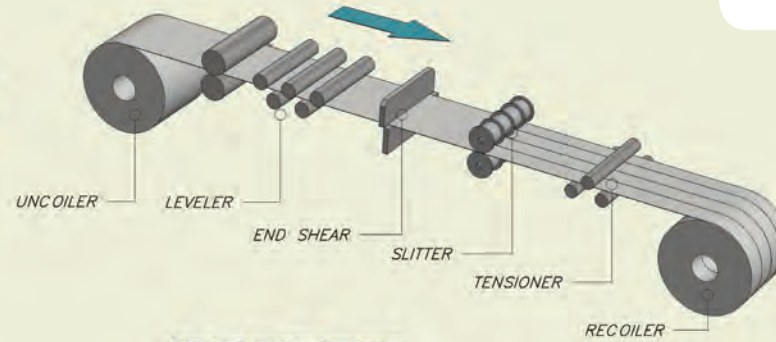

SLITTED COIL

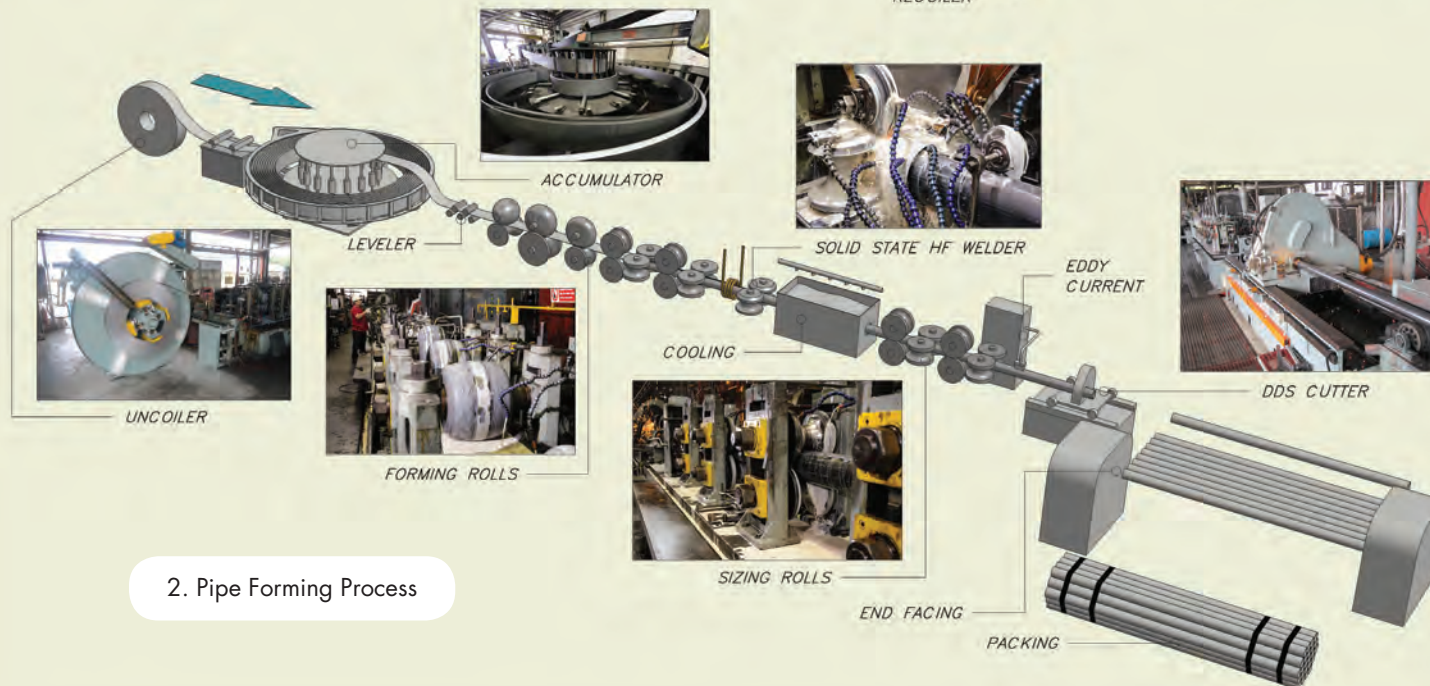

## 2. Pipe Forming Process



# MILL PROCESSING FLOW

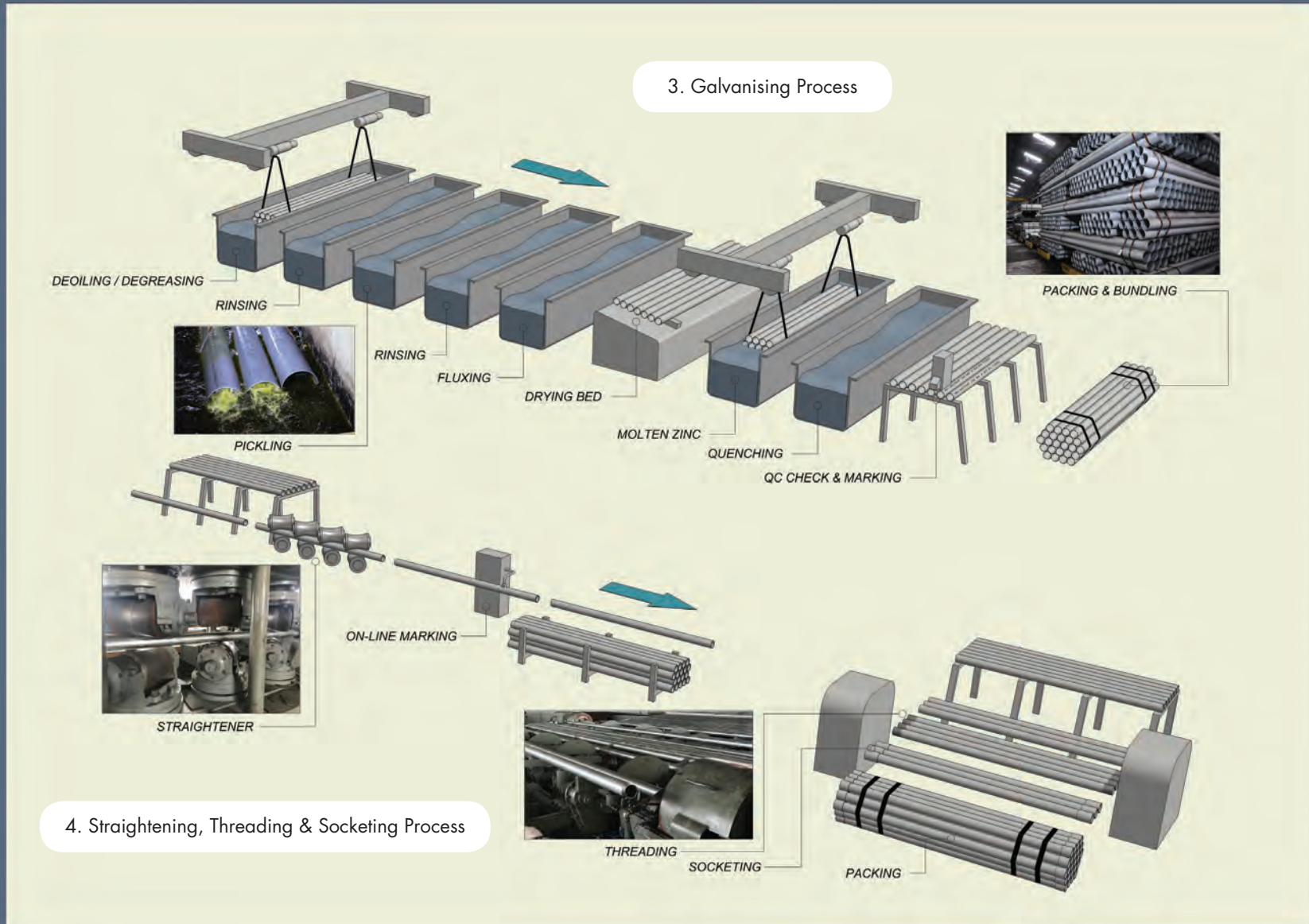



# QUALITY PRODUCTS



Black Welded Steel Pipe

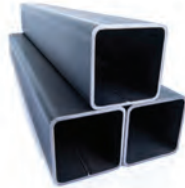

Square Hollow Section



Rectangular Hollow Section



Hot Dipped Galvanised Pipe



Electrical Steel Conduit



Cold Rolled Tubes



D Tube



Oblong Tubes

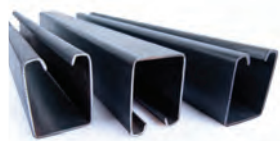

Door Rail Track



Gate Channel

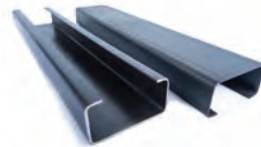

Lip Channel

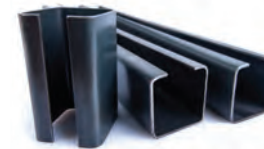

Trolley Track



U Channel



# QUICK SEARCH

All our tubes are referenced by their Tube Reference Numbers (TRN)

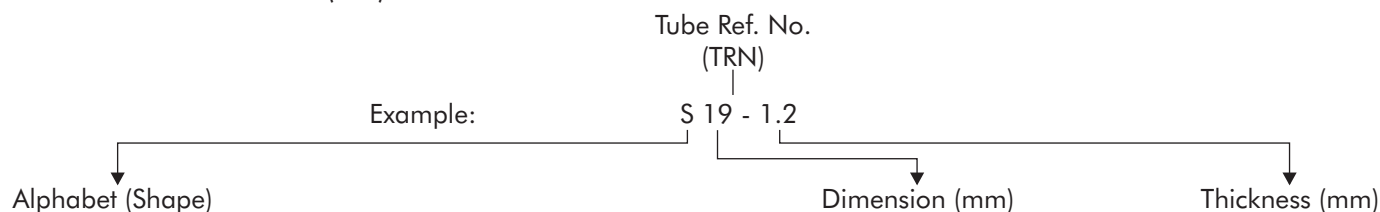

Tube Ref.No.(TRN):	Alphabet (Shape)	- C-Circular, S-Square, R-Rectangular, CC-C Channel, LC-Lip Channel
	Dimension (mm)	- All Dimensions are to 1 decimal place (except for Channels & Special Sizes which are to 0 decimal place).
	Thickness (mm)	- All Thickness are to 1 decimal place.

## DIFFERENCE BETWEEN A PIPE AND A TUBE









Although pipes and tubes may seem similar, they are in fact quite different in nomenclature and sizing. Pipes and tubes are rarely interchangeable! Here are some of the main differences between the two products:

Pipes are always round in shape. Tubes can be square, rectangular or round.

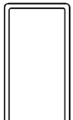
Tubes are typically rigid; however, copper and brass tubes can be shaped relatively easily. Pipes are invariably rigid and cannot be shaped without special equipment. Measurements. Pipes are only provided with an inside (nominal) diameter and a "schedule" (which means wall thickness). Tube measurements are provided as an outside diameter and set ranges of wall thickness.

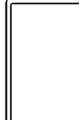
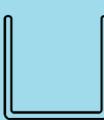
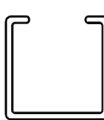
Pipe is typically available in larger sizes than tube.

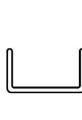
Only pipes are pressure rated and intended to be used for the transference of fluids or gas. Tubes, on the other hand, are used in structural applications.

Shape													
Shape Name		Circular Hollow Section (C)	Galvanised Conduit (CON)	Square Hollow Section (S)	Rectangular Hollow Section (R)	Lipped Channel (LC)	Plain C-Channel (CC)	U-Channel (UC)	Trolley Track (TT)	Door Rail Track (DR)	Gate Channel (GC)	Oblong Tube (OT)	D-Tube (DT)
Largest	mm	406.4	50.8	250 X 250	300 X 200	250 X 75 X 25	250 X 75	30 X 30	50 X 50 X 15	44 X 65 X 15	10 X 19 X 10	59 X 30	50 X 25
Smallest	mm	9.5	19.1	12 X 12	19 X 9	100 X 50 X 20	60 X 30	25 X 25	50 X 50 X 15	44 X 65 X 15	10 X 19 X 10	19 X 10	50 X 25
Thickest	mm	7.9	2.0	10.0	10.0	4.5	4.5	1.5	3.0	2.3	2.3	2.3	1.2
Thinnest	mm	1.0	1.6	1.0	1.0	2.3	1.6	1.5	1.5	1.5	2.3	0.7	1.2



# PRODUCT SPECIFICATION TABLE

Specification	Shapes	Grade	Chemical Composition % (Max)					Mechanical Properties (Min)		
			C	Si	Mn	P	S	Yield (MPa)	Tensile (MPa)	Elongation %
MS 863:2010 / BS EN 10255:2004	Round	L1,L2,M,H	0.20	-	1.40	0.035	0.030	195	320 - 520	20
JIS G 3452:2010	Round	-	-	-	-	0.040	0.040	-	290	30
MS 1462-2-1:2010 / BS EN 39:2001	Round	S235GT	0.20	0.04	1.40	0.040	0.045	235	340 - 520	24
BS 534:1990	Round	430	0.21	0.35	0.40 - 1.20	0.040	0.040	275	430 - 570	22
SPAN TS 21827:part 2:2013 / BS EN 10224:2002	Round	L 235	0.16	0.35	1.20	0.030	0.025	235	360 - 500	25 <sup>A</sup> , 23 <sup>B</sup>
		L 275	0.20	0.40	1.40	0.030	0.025	275	410 - 560	21 <sup>A</sup> , 19 <sup>B</sup>
		L 355	0.22	0.55	1.60	0.030	0.025	355	500 - 650	21 <sup>A</sup> , 19 <sup>B</sup>
BS 31:1940 (Conduit : Imperial)	Round	-	-	-	-	-	-	-	278 - 371	15
ASTM A500/ A500M	Round	A	0.26	-	1.35	0.035	0.035	230	310	25
		B	0.26	-	1.35	0.035	0.035	290	400	23
		C	0.23	-	1.35	0.035	0.035	315	425	21
		D	0.26	-	1.35	0.035	0.035	250	400	23
	Square, Rectangular	A	0.26	-	1.35	0.035	0.035	270	310	25
		B	0.26	-	1.35	0.035	0.035	315	400	23
		C	0.23	-	1.35	0.035	0.035	345	425	21
		D	0.26	-	1.35	0.035	0.035	250	400	23



# PRODUCT SPECIFICATION TABLE

Specification	Shapes	Grade	Chemical Composition % (Max)					Mechanical Properties (Min)		
			C	Si	Mn	P	S	Yield (MPa)	Tensile (MPa)	Elongation %
BS EN 10219:2006 / MS EN 10219:2015	Round, Square, Rectangular	S235	0.17	-	1.40	0.040	0.040	235	360-510 <sup>(-)</sup> , 360-510 <sup>(+)</sup>	24
		S275	0.20	-	1.50	0.035	0.035	275	430-580 <sup>(-)</sup> , 410-560 <sup>(+)</sup>	20
		S355	0.22	0.55	1.60	0.035	0.035	355	510-680 <sup>(-)</sup> , 470-630 <sup>(+)</sup>	20
AS 1163:2009	*Round, Square, Rectangular	250	0.12	0.05	0.50	0.030	0.030	250	320	*22, 18
		350	0.20	0.45	1.60	0.030	0.030	350	430	*20, 16
		450	0.20	0.45	1.70	0.030	0.030	450	500	*16, 14
JIS G 3466:2006	Square, Rectangular	STKR 400	0.25	-	-	0.040	0.040	245	400	23
		STKR 490	0.18	0.55	1.50	0.040	0.040	325	490	23
JIS G 3444:2010	Round	STK 290	-	-	-	0.050	0.050	-	290	30 <sup>A</sup> , 25 <sup>B</sup>
		STK 400	0.25	-	-	0.040	0.040	235	400	23 <sup>A</sup> , 18 <sup>B</sup>
		STK 490	0.18	0.55	1.50	0.040	0.040	315	490	23 <sup>A</sup> , 18 <sup>B</sup>
		STK 500	0.24	0.35	0.30 - 1.30	0.040	0.040	355	500	15 <sup>A</sup> , 10 <sup>B</sup>
JIS G 3445:2006	Round	STKM 11A	0.12	0.35	0.60	0.040	0.040	-	290	30
JIS G 3472:2007	Round	STAM290GA	0.12	0.35	0.60	0.035	0.035	175	290	40
		STAM290GB								35
JIS G 3350:2009	Channel	SSC 400	0.25	-	-	0.050	0.050	245	400 - 540	21
ASTM A 252-98 (2007)	Round	Grade 1	-	-	-	0.050	-	205	345	30 (Gauge length:2")
		Grade 2	-	-	-	0.050	-	240	415	25 (Gauge length:2")
		Grade 3	-	-	-	0.050	-	310	455	20 (Gauge length:2")

Remarks: A = longitudinal direction, B = Transverse direction, (-) = T < 3mm, (+) = 3mm ≤ T ≤ 40mm



# Technical Details Of BS EN 10255 : 2004 (supersedes BS 1387 : 1985)

## WELDED STEEL PIPES - TYPE L2 (LIGHT SERIES), MEDIUM SERIES, HEAVY SERIES & TYPE L1

Our Black and Galvanised pipes are produced to MS 863 : 2010 / BS EN 10255 : 2004 / BS 1387 : 1985 / MANUFACTURER'S STANDARD on our precision electric-resistance-weld tube mills, by using prime quality steel.

(GENERAL INFORMATION ON BS EN 10255 : 2004 [SUPERSEDES BS 1387 : 1985] WELDED STEEL TUBE)

DESCRIPTIONS	MIG - MELEWAR BS EN 10255 : 2004 (BS 1387 :1985) welded steel tube is produced in three series : Type L2 (Light Series), Medium, Heavy & Type L1. The tubes are available in black finished or hot-dipped galvanised finished in 6 meter or 6.4 meter uniform standard lengths.
APPLICATIONS	For ordinary conveyance of steam, gas, air, water, etc.
END FINISH AND PROTECTION	Plain-end square-cut (PE) or Threaded and socketed (T/C). PE tubes are chipped without any protection on both ends.T/C tubes are supplied screwed with taper threads to BS EN 10226 - 1 (BS 21) and fitted with one parallel-threaded malleable iron socket, as required under this specification.
IDENTIFICATION MARKING	Tubes are marked by colour bands about 50mm wide, about 300mm from each end, as follow: Type L2 (Light) - Brown                      Medium - Blue Heavy                      - Red                      Type L1 - White



**PERTINENT EXCERPTS FROM BS EN 10255 : 2004  
(supersedes BS 1387 : 1985) SPECIFICATION**

CHEMICAL COMPOSITION	The chemical composition of the steel, by cast analysis, shall comply with the below: Carbon, C : 0.20% max Manganese, Mn : 1.40% max Phosphorus, P : 0.035% max Sulphur, S : 0.030% max
MECHANICAL PROPERTIES	The mechanical properties at room temperature shall be as given below: Yield Strength (MPa) : 195 min Tensile Strength (MPa) : 320 to 520 Elongation on gauge length $L_0 = 5.65 \sqrt{S_0}$ (%) : 20% min
TOLERANCES ON DIMENSION AND MASS	Outside Diameter : As shown in Table on page 16 - 19 Wall thickness : Type L2 (Light tubes) - 8% : Medium and Heavy tubes $\pm 10\%$ : Type L1 - 8% Mass : + 10% or - 8% on individual tubes for Type L1 & L2 : $\pm 7.5\%$ on bundles of 10 tons or more, for Medium and Heavy tubes
BEND TEST	The bend test shall applied to bare tubes with specified outside diameter (D) of 17.2mm up to and including 60.3mm and shall be carried out in accordance with EN 10232 to an angle of 90°. The groove in the forming tool shall have a width that fits the tube diameter accurately and a depth not less than 0.5 D.
FLATTENING TEST	The flattening test shall applied to bare tubes with specified outside diameter (D) greater than 60.3mm and shall be carried out in accordance with EN 10233. Welded tubes shall be flattened with the weld placed alternately at 0 or 90° (12 or 3 o'clock) to the direction of the flattening. The tube shall be flattened in a press until the distance between platens, measured under load, reaches 75% of the original outside diameter of the tube. The tube shall show no cracks or flaws visible without magnifying aids. No cracks or flaws visible without magnifying aids shall occur in the metal other than in the weld until the distance between platens, measured under load, reaches 60% of the original outside diameter.
LEAK TIGHTNESS TEST	At the discretion of the manufacturer, the test can be either a hydrostatic test at a minimum of 50 bar for at least 5 s , or an automatic electromagnetic testing.

*NOTE: Special tubes sizes not stipulated in the BS specification may be made available upon request. Please feel free to enquire.*



# WELDED STEEL PIPES : TYPE L2 (LIGHT SERIES)

MS 863 : 2010 / BS EN 10255 : 2004 / BS 1387 : 1985 ( A ) / MANUFACTURER'S STANDARD

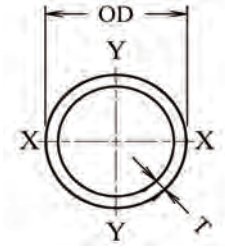

TUBE REF. NO. (TRN)	NOMINAL DIAMETER DN	SPECIFIED OUTSIDE DIAMETER D	THREAD SIZE R	OUTSIDE DIAMETER		WALL THICKNESS T	CALCULATED MASS		NUMBER OF THREADS PER INCH	SOCKET LENGTH	TEST PRESSURE
				max	min		PLAIN END	THREADED & SOCKETED			
		mm		mm	mm	mm	kg/m	kg/m		min	
C21.3-2.0	15	21.3	1/2	21.4	21.0	2.0	0.947	0.956	14	34.0	50
C26.9-2.3	20	26.9	3/4	26.9	26.4	2.3	1.380	1.390	14	37.0	50
C33.7-2.6	25	33.7	1	33.8	33.2	2.6	1.980	2.000	11	43.0	50
C42.4-2.6	32	42.4	1 1/4	42.5	41.9	2.6	2.540	2.570	11	48.0	50
C48.3-2.9	40	48.3	1 1/2	48.4	47.8	2.9	3.230	3.270	11	52.5	50
C60.3-2.9	50	60.3	2	60.2	59.6	2.9	4.080	4.150	11	62.5	50
C76.1-3.2	65	76.1	2 1/2	76.0	75.2	3.2	5.710	5.830	11	71.5	50
C88.9-3.2	80	88.9	3	88.7	87.9	3.2	6.720	6.890	11	77.0	50
C114.3-3.6	100	114.3	4	113.9	113.0	3.6	9.750	10.000	11	91.0	50

# WELDED STEEL PIPES : MEDIUM SERIES ( M )

MS 863 : 2010 / BS EN 10255 : 2004 / BS 1387 : 1985 ( B ) / MANUFACTURER'S STANDARD

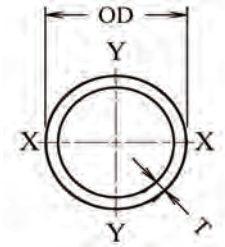

TUBE REF. NO. (TRN)	NOMINAL DIAMETER DN	SPECIFIED OUTSIDE DIAMETER D	THREAD SIZE R	OUTSIDE DIAMETER		WALL THICKNESS T	CALCULATED MASS		NUMBER OF THREADS PER INCH	SOCKET LENGTH	TEST PRESSURE
				max	min		PLAIN END	THREADED & SOCKETED		min	
		mm		mm	mm	mm	kg/m	kg/m		mm	
C21.3-2.6	15	21.3	1/2	21.8	21.0	2.6	1.210	1.220	14	34.0	50
C26.9-2.6	20	26.9	3/4	27.3	26.5	2.6	1.560	1.570	14	37.0	50
C33.7-3.2	25	33.7	1	34.2	33.3	3.2	2.410	2.430	11	43.0	50
C42.4-3.2	32	42.4	1 1/4	42.9	42.0	3.2	3.100	3.130	11	48.0	50
C48.3-3.2	40	48.3	1 1/2	48.8	47.9	3.2	3.560	3.600	11	52.5	50
C60.3-3.6	50	60.3	2	60.8	59.7	3.6	5.030	5.100	11	62.5	50
C76.1-3.6	65	76.1	2 1/2	76.6	75.3	3.6	6.420	6.540	11	71.5	50
C88.9-4.0	80	88.9	3	89.5	88.0	4.0	8.360	8.530	11	77.0	50
C114.3-4.5	100	114.3	4	115.0	113.1	4.5	12.200	12.500	11	91.0	50
C139.7-5.0	125	139.7	5	140.8	138.5	5.0	16.600	17.100	11	105.5	50
C165.1-5.0	150	165.1	6	166.5	163.9	5.0	19.800	20.400	11	116.5	50



# WELDED STEEL PIPES : HEAVY SERIES ( H )

MS 863 : 2010 / BS EN 10255 : 2004 / BS 1387 : 1985 ( C ) / MANUFACTURER'S STANDARD

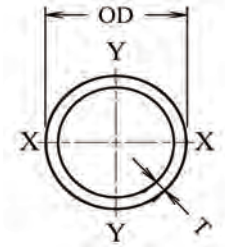

TUBE REF. NO. (TRN)	NOMINAL DIAMETER DN	SPECIFIED OUTSIDE DIAMETER D	THREAD SIZE R	OUTSIDE DIAMETER		WALL THICKNESS T	CALCULATED MASS		NUMBER OF THREADS PER INCH	SOCKET LENGTH	TEST PRESSURE
				max	min		PLAIN END	THREADED & SOCKETED		min	
		mm		mm	mm	mm	kg/m	kg/m		mm	
C21.3-3.2	15	21.3	1/2	21.8	21.0	3.2	1.440	1.450	14	34.0	50
C26.9-3.2	20	26.9	3/4	27.3	26.5	3.2	1.870	1.880	14	37.0	50
C33.7-4.0	25	33.7	1	34.2	33.3	4.0	2.930	2.950	11	43.0	50
C42.4-4.0	32	42.4	1 1/4	42.9	42.0	4.0	3.790	3.820	11	48.0	50
C48.3-4.0	40	48.3	1 1/2	48.8	47.9	4.0	4.370	4.410	11	52.5	50
C60.3-4.5	50	60.3	2	60.8	59.7	4.5	6.190	6.260	11	62.5	50
C76.1-4.5	65	76.1	2 1/2	76.6	75.3	4.5	7.930	8.050	11	71.5	50
C88.9-5.0	80	88.9	3	89.5	88.0	5.0	10.300	10.500	11	77.0	50
C114.3-5.4	100	114.3	4	115.0	113.1	5.4	14.500	14.800	11	91.0	50
C139.7-5.4	125	139.7	5	140.8	138.5	5.4	17.900	18.400	11	105.5	50
C165.1-5.4	150	165.1	6	166.5	163.9	5.4	21.300	21.900	11	116.5	50

# WELDED STEEL PIPES : TYPE L1

MS 863 : 2010 /BS EN 10255 : 2004

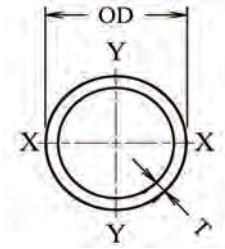

TUBE REF. NO. (TRN)	NOMINAL DIAMETER DN	SPECIFIED OUTSIDE DIAMETER D	THREAD SIZE R	OUTSIDE DIAMETER		WALL THICKNESS T	CALCULATED MASS		NUMBER OF THREADS PER INCH	SOCKET LENGTH	TEST PRESSURE
				max	min		PLAIN END	THREADED & SOCKETED			
				mm	mm		mm	mm		kg/m	
C21.3-2.3	15	21.3	1/2	21.7	21.0	2.3	1.080	1.090	14	34.0	50
C26.9-2.3	20	26.9	3/4	27.1	26.4	2.3	1.390	1.400	14	37.0	50
C33.7-2.9	25	33.7	1	34.0	33.2	2.9	2.200	2.220	11	43.0	50
C42.4-2.9	32	42.4	1 1/4	42.7	41.9	2.9	2.820	2.850	11	48.0	50
C48.3-2.9	40	48.3	1 1/2	48.6	47.8	2.9	3.240	3.280	11	52.5	50
C60.3-3.2	50	60.3	2	60.7	59.6	3.2	4.490	4.560	11	62.5	50
C76.1-3.2	65	76.1	2 1/2	76.3	75.2	3.2	5.730	5.850	11	71.5	50
C88.9-3.6	80	88.9	3	89.4	87.9	3.6	7.550	7.720	11	77.0	50
C114.3-4.0	100	114.3	4	114.9	113.0	4.0	10.800	11.100	11	91.0	50



# WELDED STEEL PIPES FOR GENERAL PURPOSES

CLASS AA - MANUFACTURER'S STANDARD

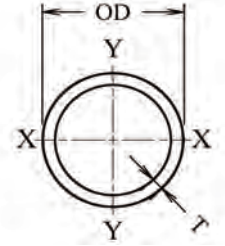

TUBE REF. NO. (TRN)	NOMINAL SIZE		NOMINAL WALL THICKNESS*	OUTSIDE DIAMETER		CALCULATED WEIGHT
				max	min	PLAIN ENDS
	mm	in		mm	mm	mm
C21.3-1.5	15	1/2	1.5	21.4	21.0	0.74
C26.9-1.5	20	3/4	1.5	26.9	26.4	0.94
C33.7-1.5	25	1	1.5	33.8	33.2	1.19
C42.4-1.5	32	1 1/4	1.5	42.5	41.9	1.52
C48.3-1.5	40	1 1/2	1.5	48.4	47.8	1.73
C60.3-1.5	50	2	1.5	60.2	59.6	2.17
C76.1-1.5	65	2 1/2	1.5	76.0	75.2	2.76
C88.9-1.9	80	3	1.9	88.7	87.9	4.07
C101.6-1.9	90	3 1/2	1.9	102.0	101.1	4.69
C114.3-1.9	100	4	1.9	113.9	113.0	5.25
C139.7-4.0	125	5	4.0	140.6	138.7	13.47
C165.1-4.0	150	6	4.0	166.1	164.1	15.99

# WELDED STEEL PIPES FOR GENERAL PURPOSES

## MANUFACTURER'S STANDARD

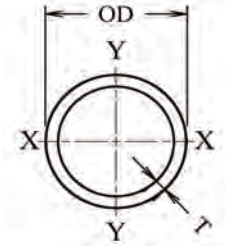

TUBE REF. NO. (TRN)	NOMINAL SIZE		NOMINAL WALL THICKNESS*	OUTSIDE DIAMETER		CALCULATED WEIGHT
				max	min	PLAIN ENDS
	mm	in	mm	mm	mm	kg/m
C101.6-3.3	90	3 1/2	3.3 (A)	101.1	100.3	7.96
C101.6-4.1			4.1 (B)	102.1	100.6	9.91
C101.6-5.1			5.1 (C)	102.1	100.6	12.20
C139.7-3.0	125	5	3.0	140.6	138.7	10.18
C139.7-3.2			3.2	140.6	138.7	10.84
C165.1-3.0	150	6	3.0	166.1	164.1	12.07
C165.1-3.2			3.2	166.1	164.1	12.85
C190.7-4.5	175	7	4.5	192.3	189.1	20.84
C216.3-4.5	200	8	4.5	218.0	214.6	23.50
C267.4-4.5	250	10	4.5	269.5	265.3	29.17
C267.4-6.0			6.0	269.5	265.3	38.68

NOTE: \* Thickness tolerances:  $\pm 12.5\%$



# CARBON STEEL PIPES FOR ORDINARY PIPING

JIS G 3452 / MANUFACTURER'S STANDARD

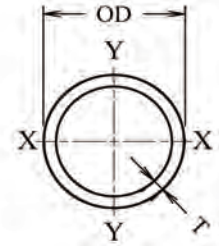

TUBE REF. NO. (TRN)	NOMINAL SIZE		OUTSIDE DIAMETER		WALL THICKNESS		WEIGHT (PLAIN ENDS)					TEST PRESSURE	
	mm	in	mm	in	mm	in	kg/m	kg/6m	kg/ft	lb/ft	lb/20ft	kg/cm <sup>2</sup>	psi
C114.3-4.5	100	4	114.3	4.500	4.5	0.177	12.20	73.20	3.72	8.20	164	25	360
C139.8-4.5	125	5	139.8	5.504	4.5	0.177	15.00	90.00	4.57	10.10	202	25	360
C165.2-5.0	150	6	165.2	6.504	5.0	0.197	19.80	118.80	6.04	13.30	266	25	360
C190.7-5.3	175	7	190.7	7.508	5.3	0.209	24.20	145.20	7.38	16.30	326	25	360
C216.3-5.8	200	8	216.3	8.516	5.8	0.228	30.10	180.60	9.17	20.20	404	25	360
C241.8-6.2	225	9	241.8	9.520	6.2	0.244	36.00	216.00	11.00	24.20	484	25	360
C267.4-6.6	250	10	267.4	10.528	6.6	0.260	42.40	254.50	12.90	28.50	570	25	360
C318.5-6.9	300	12	318.5	12.539	6.9	0.272	53.00	318.00	16.20	35.60	712	25	360
C355.6-7.9	350	14	355.6	14.000	7.9	0.311	67.70	406.20	20.60	45.50	910	25	360
C406.4-7.9	400	16	406.4	16.000	7.9	0.311	77.60	465.60	23.70	52.10	1042	25	360

**NOTE:** Thickness tolerances + Not specified  
- 12.5%

# ELECTRIC WELDED NON-ALLOY STEEL TUBES FOR CEMENT LINED PIPES

SPAN TS 21827: PART 2:2013 / BS EN 10224 / BS 534 / MANUFACTURER'S STANDARDS

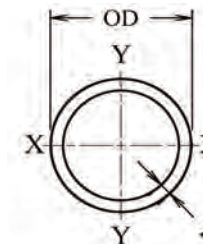

TUBE REF. NO. (TRN)	OUTSIDE DIAMETER*	MINIMUM WALL THICKNESS*	OUTSIDE DIAMETER		CALCULATED WEIGHT	MAXIMUM TEST PRESSURE
			max	min	Plain Ends	
			mm	mm	kg/m	
C114.3-3.6	114.3	3.6	115.4	113.2	9.83	70
C139.7-3.6	139.7	3.6	141.1	138.3	12.08	70
C168.3-3.6	168.3	3.6	170.0	166.6	14.62	70
C193.7-4.0	193.7	4.0	195.2	192.2	18.71	70
C219.1-4.0	219.1	4.0	221.3	216.9	21.22	70
C244.5-4.0	244.5	4.0	246.3	242.7	23.72	70
C273.0-4.0	273.0	4.0	275.0	271.0	26.53	64
C323.9-4.0	323.9	4.0	326.3	321.5	31.55	54
C355.6-4.5	355.6	4.5	358.3	352.9	38.96	56

NOTE: \* Other diameters and / or thicknesses may be available by agreement with the manufacturer.  
 Sizes with shaded are uncommon size

The following sizes are also available upon request:

TUBE REF. NO. (TRN)	OUTSIDE DIAMETER*	MINIMUM WALL THICKNESS*	OUTSIDE DIAMETER		CALCULATED WEIGHT
			max	min	Plain Ends
			mm	mm	kg/m
C121.9-4.1	121.9	4.1	123.1	120.7	11.91
C152.4-4.0	152.4	4.0	153.9	150.9	14.64
C177.3-4.1	177.3	4.1	178.6	176.0	17.51
C232.2-4.1	232.2	4.1	233.9	230.5	23.06
C286.0-4.1	286.0	4.1	288.2	283.9	28.50
C345.4-5.8	345.4	5.8	348.0	342.8	48.57

NOTE: Sizes with shaded are uncommon size



# BRITISH STANDARD STEEL TUBES FOR SCAFFOLDING

MS 1462-1:2012/ BS EN 39:2001/ BS 1139:Section 1.1:1990

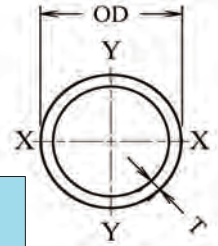

TUBE REF. NO. (TRN)	TYPE	NOMINAL SIZE	OUTSIDE DIAMETER		WALL THICKNESS*	CALCULATED WEIGHT	CROSS-SECTIONAL AREA	SECOND MOMENT OF INERTIA	SECTION OF MODULUS OF AREA	RADIUS OF GYRATION	PLASTIC MODULUS
			MAX	MIN							
		mm	mm	mm	mm	kg/m	cm <sup>2</sup>	cm <sup>4</sup>	cm <sup>3</sup>	cm	cm <sup>3</sup>
C48.3-3.2	3	48.3	48.8	47.8	3.2	3.56	4.53	11.60	4.80	1.60	6.52
C48.3-4.0	4				4.0	4.37	5.57	13.80	5.70	1.57	7.87

Note: \* Thickness tolerances:  $\pm 10\%$

# CARBON STEEL TUBES FOR GENERAL STRUCTURAL PURPOSE

JIS G 3444:2010 (STK 290/400/500/540)

TUBE REF. NO. (TRN)	NOMINAL SIZE	WALL THICKNESS	CALCULATED WEIGHT	CROSS-SECTIONAL AREA	GEOMETRICAL MOMENT OF INERTIA	MODULUS OF SECTION	RADIUS OF GYRATION OF AREA
	mm	mm	kg/mm	cm <sup>2</sup>	cm <sup>4</sup>	cm <sup>3</sup>	cm
C21.7-2.0	21.7	2.0	0.972	1.238	0.607	0.560	0.700
C27.2-2.0	27.2	2.0	1.240	1.583	1.260	0.930	0.890
C42.7-2.5	42.7	2.5	2.480	3.157	6.400	3.000	1.420

Note: \* Thickness tolerances:  $\pm 0.3\text{mm}$

# AURORA BRAND BRITISH STANDARD GALVANISED STEEL CONDUIT

BS 31 CLASS 3 (SCREWED)/MANUFACTURER'S STANDARD

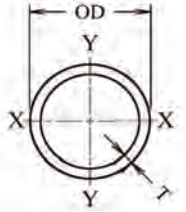

TUBE REF. NO. (TRN)	NOMINAL SIZE	OUTSIDE DIAMETER				WALL THICKNESS				CALCULATED WEIGHT WITH COUPLER			NUMBERS OF THREADS	LENGTH OF THREADS			
		MAXIMUM		MINIMUM		NOMINAL		MINIMUM		mm	in	mm		MAXIMUM		MINIMUM	
		mm	in	mm	in	mm	in	mm	in	kg/m	kg/ft	lb/ft	PER INCH	mm	in	mm	in
CON 19.0-1.6	3/4	19.05	0.750	18.76	0.739	1.63	0.064	1.52	0.060	0.713	0.217	0.479	16	14.3	0.5626	12.7	0.5000
CON 25.4-1.6	1	25.40	1.000	25.11	0.989	1.63	0.064	1.52	0.060	0.972	0.296	0.653	16	17.5	0.6875	15.9	0.6250
CON 31.7-1.6	1 1/4	31.75	1.250	31.46	1.239	1.63	0.064	1.52	0.060	1.240	0.376	0.830	16	19.1	0.7500	17.5	0.6875
CON 38.1-1.8	1 1/2	38.10	1.500	37.80	1.488	1.83	0.072	1.73	0.068	1.680	0.511	1.130	14	20.6	0.8125	19.1	0.7500
CON 50.8-2.0	2	50.80	2.000	50.50	1.988	2.03	0.080	1.93	0.076	2.510	0.765	1.690	14	23.8	0.9375	22.2	0.8750

Standard Length 3.810 m (12ft. 6 in) without couples

## FEATURES :

- \* Made of hot - dipped galvanised steel strip with extra- smooth surface and highly - adherent zinc coating by the unique tube - making process. The weld zone coating restored in line.
- \* Inside weld bead controlled to a minimum for easier wire pulling.
- \* Screwed on both ends to BS31 and fitted with a zinc - coated coupler or one end.
- \* Packed in bare bundles, but the unsocketed ends protected with plastic caps.
- \* Easier to cut, thread, bend and pull. Dimensionally accurate. Uniform quality in every respect.



# AURORA BRAND BRITISH STANDARD. GALVANISED STEEL CONDUIT

MS 275 / BS 4568 CLASS 3 (SCREWED) / MANUFACTURER'S STANDARD

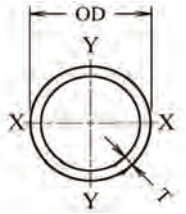

TUBE REF. NO. (TRN)	NOMINAL SIZE	OUTSIDE DIAMETER		WALL THICKNESS	CALCULATED WEIGHT WITH COUPLER		PITCH	LENGTH OF THREADS	
		MAXIMUM	MINIMUM		MAXIMUM	MINIMUM		MAXIMUM	MINIMUM
	mm	mm	mm	mm	kg/m	kg/m	mm	mm	mm
CON 20.0-1.6	20	20	19.7	1.6 ± 0.15	0.783	0.643	1.5	15	13
CON 25.0-1.6	25	25	24.6	1.6 ± 0.15	0.995	0.811	1.5	18	16
CON 32.0-1.6	32	32	31.6	1.6 ± 0.15	1.301	1.069	1.5	20	18

Standard Length 3.810 m without couples ( Minimum 3.0 m, Maximum 4.0 m)

## CONDUIT SYSTEMS FOR CABLE MANAGEMENT

MS IEC 61386-1/ MS 61386-21

Classification: 441611403410

TUBE REF. NO. (TRN)	NOMINAL SIZE	OUTSIDE DIAMETER		INSIDE DIAMETER	EXTERNAL THREAD LENGTH
		Max	Min	Min	Min
	mm	mm	mm	mm	mm
CON 20.0-1.6	20	20.0	19.7	16.2	14.0
CON 25.0-1.6	25	25.0	24.6	21.1	17.0
CON 32.0-1.6	32	32.0	31.6	28.1	19.0

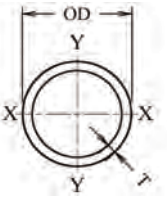

# ELECTRIC RESISTANCE WELDED STEEL PIPE PILES

ASTM A 252 - Grade 1, Grade 2 & Grade 3

TUBE REF. NO. (TRN)	SPECIFIED OUTSIDE DIAMETER		OUTSIDE DIAMETER TOLERANCE		Nominal Wall Thickness		Weight per unit length	Cross Sectional Area	Second Moment Of Area	Radius Of Gyration	Elastic Section Modulus	Plastic Section Modulus	Torsional Inertia Constant	Torsional Modulus Constant	Superficial Area per metre length
	D		max	min	T	min	M	A	I	i	W <sub>el</sub>	W <sub>pl</sub>	I <sub>t</sub>	C <sub>t</sub>	A <sub>s</sub>
	inch	mm	mm	mm	mm	mm	kg/m	cm <sup>2</sup>	cm <sup>4</sup>	cm	cm <sup>3</sup>	cm <sup>3</sup>	cm <sup>4</sup>	cm <sup>3</sup>	m <sup>2</sup> /m
C152.4-3.4	6	152.4	153.92	150.88	3.40	2.98	12.50	15.92	442	5.27	58.0	75.5	884	115.98	0.479
C152.4-3.6					3.58	3.13	13.10	16.74	464	5.26	60.8	79.3	927	121.69	0.479
C152.4-4.0					3.96	3.47	14.50	18.47	509	5.25	66.8	87.3	1018	133.60	0.479
C152.4-4.2					4.17	3.64	15.20	19.42	534	5.24	70.0	91.6	1068	140.10	0.479
C152.4-4.4					4.37	3.82	16.00	20.32	557	5.24	73.1	95.8	1114	146.23	0.479
C219.1-4.8	8 5/8	219.1	221.27	216.88	4.78	4.18	25.20	32.18	1849	7.58	168.8	219.6	3698	337.53	0.688
C219.1-5.2					5.16	4.51	27.20	34.68	1985	7.57	181.2	236.2	3971	362.46	0.688
C219.1-5.6					5.56	4.87	29.30	37.30	2127	7.55	194.2	253.6	4255	388.40	0.688
C219.1-6.4					6.35	5.56	33.30	42.44	2403	7.53	219.4	287.5	4807	438.78	0.688
C219.1-7.0					7.04	6.16	36.80	46.90	2639	7.50	240.9	316.7	5279	481.84	0.688
C219.1-7.9					7.92	6.93	41.20	52.54	2933	7.47	267.8	353.4	5867	535.51	0.688
C219.1-8.2					8.18	7.16	42.50	54.20	3019	7.46	275.6	364.1	6037	551.11	0.688
C219.1-8.7					8.74	7.65	45.30	57.76	3200	7.44	292.1	387.0	6401	584.29	0.688
C219.1-9.5					9.52	8.33	49.20	62.68	3449	7.42	314.8	418.4	6897	629.59	0.688
C273.1-4.8	10 3/4	273.1	275.78	270.32	4.78	4.18	31.60	40.29	3627	9.49	265.6	344.2	7255	531.28	0.858
C273.1-5.2					5.16	4.51	34.10	43.43	3899	9.47	285.6	370.5	7799	571.11	0.858
C273.1-5.6					5.56	4.87	36.70	46.73	4183	9.46	306.3	398.0	8366	612.67	0.858

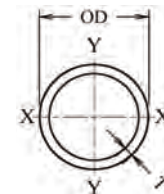

# ELECTRIC RESISTANCE WELDED STEEL PIPE PILES

ASTM A 252 - Grade 1, Grade 2 & Grade 3

TUBE REF. NO. (TRN)	SPECIFIED OUTSIDE DIAMETE		OUTSIDE DIAMETER TOLERANCE		Nominal Wall Thickness		Weight per unit length	Cross Sectional Area	Second Moment Of Area	Radius Of Gyration	Elastic Section Modulus	Plastic Section Modulus	Torsional Inertia Constant	Torsional Modulus Constant	Superficial Area per metre length
	D		max	min	T	min	M	A	I	i	W <sub>el</sub>	W <sub>pl</sub>	I <sub>t</sub>	C <sub>t</sub>	A <sub>s</sub>
	inch	mm	mm	mm	mm	mm	kg/m	cm <sup>2</sup>	cm <sup>4</sup>	cm	cm <sup>3</sup>	cm <sup>3</sup>	cm <sup>4</sup>	cm <sup>3</sup>	m <sup>2</sup> /m
C273.1-5.8	10 <sup>3/4</sup>	273.1	275.78	270.32	5.84	5.11	38.50	49.03	4380	9.45	320.8	417.2	8760	641.53	0.858
C273.1-6.4					6.35	5.56	41.70	53.21	4736	9.43	346.8	451.9	9472	693.64	0.858
C273.1-7.1					7.09	6.20	46.60	59.25	5245	9.41	384.1	501.8	10489	768.15	0.858
C273.1-7.8					7.80	6.82	51.00	65.01	5725	9.38	419.2	549.2	11449	838.46	0.858
C273.1-8.7					8.74	7.65	57.00	72.59	6348	9.35	464.9	611.0	12696	929.76	0.858
C273.1-9.3					9.27	8.11	60.30	76.83	6693	9.33	490.2	645.5	13387	980.36	0.858
C323.9-6.4	12 <sup>3/4</sup>	323.9	327.09	320.61	6.35	5.56	49.70	63.35	7988	11.23	493.2	640.4	15976	986.49	1.018
C323.9-7.1					7.14	6.25	55.50	71.05	8916	11.20	550.5	716.5	17832	1101.08	1.018
C323.9-7.9					7.92	6.93	61.70	78.62	9818	11.18	606.3	790.9	19637	1212.51	1.018
C323.9-8.4					8.38	7.33	65.20	83.07	10344	11.16	638.7	834.4	20688	1277.44	1.018
C323.9-8.7					8.74	7.65	67.90	86.54	10752	11.15	663.9	868.3	21504	1327.85	1.018
C323.9-9.5					9.52	8.33	73.80	94.02	11627	11.12	717.9	941.2	23254	1435.85	1.018
C355.6-7.1	14	355.6	359.16	352.04	7.14	6.25	61.10	78.16	11869	12.32	667.5	867.1	23737	1335.05	1.117
C355.6-7.9					7.92	6.93	67.90	86.51	13078	12.30	735.6	957.5	26156	1471.12	1.117
C355.6-8.7					8.74	7.65	74.70	95.24	14332	12.27	806.1	1051.7	28664	1612.16	1.117
C355.6-9.5					9.52	8.33	81.20	103.51	15508	12.24	872.2	1140.5	31016	1744.43	1.117



# SQUARE HOLLOW SECTIONS

ASTM A500/ A500M GRADES A & B / MANUFACTURER'S STANDARD

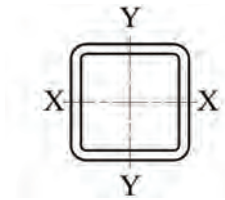

TUBE REF. NO. (TRN)		SIZE		WALL THICKNESS		CALCULATED WEIGHT		AREA	MOMENT OF INERTIA		SECTION MODULUS		RADIUS OF GYRATION		PLASTIC MODULUS	
		NOMINAL	ACTUAL						I <sub>x</sub>	I <sub>y</sub>	Z <sub>x</sub>	Z <sub>y</sub>	i <sub>x</sub>	i <sub>y</sub>	S <sub>x</sub>	S <sub>y</sub>
ASTM A500	ASTM A500M	mm	in	mm	in	kg/m	kg/6m	cm <sup>2</sup>	cm <sup>4</sup>	cm <sup>4</sup>	cm <sup>3</sup>	cm <sup>3</sup>	cm	cm	cm <sup>3</sup>	cm <sup>3</sup>
S12.7-1.0	S12.0-1.0	12 x 12	1/2 x 1/2	1.0	0.039	0.36	2.15	0.46	0.10	0.10	0.16	0.16	0.48	0.48	0.20	0.20
S12.7-1.2	S12.0-1.2			1.2	0.047	0.42	2.53	0.54	0.12	0.12	0.19	0.19	0.47	0.47	0.23	0.23
S12.7-1.6	S12.0-1.6			1.6	0.063	0.54	3.25	0.69	0.14	0.14	0.22	0.22	0.45	0.45	0.29	0.29
S15.9-1.0	S16.0-1.0	16 x 16	5/8 x 5/8	1.0	0.039	0.46	2.74	0.58	0.21	0.21	0.27	0.27	0.61	0.61	0.32	0.32
S15.9-1.2	S16.0-1.2			1.2	0.047	0.54	3.25	0.69	0.25	0.25	0.31	0.31	0.60	0.60	0.38	0.38
S15.9-1.6	S16.0-1.6			1.6	0.063	0.70	4.19	0.89	0.30	0.30	0.38	0.38	0.58	0.58	0.48	0.48
S19.1-1.0	S19.0-1.0	19 x 19	3/4 x 3/4	1.0	0.039	0.56	3.34	0.71	0.38	0.38	0.40	0.40	0.74	0.74	0.48	0.48
S19.1-1.2	S19.0-1.2			1.2	0.047	0.66	3.95	0.84	0.45	0.45	0.47	0.47	0.73	0.73	0.56	0.56
S19.1-1.6	S19.0-1.6			1.6	0.063	0.86	5.17	1.10	0.55	0.55	0.58	0.58	0.71	0.71	0.71	0.71
S25.4-1.0	S25.0-1.0	25 x 25	1 x 1	1.0	0.039	0.75	4.53	0.96	0.95	0.95	0.75	0.75	1.00	1.00	0.88	0.88
S25.4-1.2	S25.0-1.2			1.2	0.047	0.90	5.38	1.14	1.11	1.11	0.88	0.88	0.99	0.99	1.04	1.04
S25.4-1.6	S25.0-1.6			1.6	0.063	1.16	6.97	1.48	1.34	1.34	1.07	1.07	2.41	2.41	1.29	1.29
S25.4-2.3	S25.0-2.3			2.3	0.091	1.60	9.61	2.04	1.75	1.75	1.40	1.40	2.36	2.36	1.73	1.73
S25.4-3.0	S25.0-3.0			3.0	0.118	2.01	12.06	2.56	2.06	2.06	1.65	1.65	2.29	2.29	2.10	2.10
S25.4-3.2	S25.0-3.2			3.2	0.126	2.15	12.88	2.74	2.25	2.25	1.77	1.77	0.91	0.91	2.26	2.26
S31.7-1.2	S32.0-1.2	32 x 32	1 1/4 x 1 1/4	1.2	0.047	1.13	6.81	1.45	2.24	2.24	1.41	1.41	1.24	1.24	1.66	1.66
S31.7-1.6	S32.0-1.6			1.6	0.063	1.51	9.04	1.92	2.95	2.95	1.84	1.84	1.24	1.24	2.19	2.19
S31.7-2.3	S32.0-2.3			2.3	0.091	2.11	12.67	2.69	3.93	3.93	2.46	2.46	1.21	1.21	2.98	2.98
S31.7-3.0	S32.0-3.0			3.0	0.118	2.67	16.01	3.40	4.75	4.75	2.97	2.97	1.18	1.18	3.68	3.68
S31.7-3.2	S32.0-3.2			3.2	0.126	2.83	16.96	3.60	4.95	4.95	3.10	3.10	1.17	1.17	3.86	3.86

# SQUARE HOLLOW SECTIONS

ASTM A500/ A500M GRADES A & B / MANUFACTURER'S STANDARD

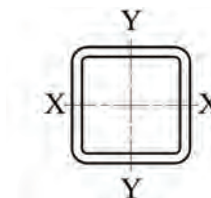

TUBE REF. NO. (TRN)		SIZE		WALL THICKNESS		CALCULATED WEIGHT		AREA	MOMENT OF INERTIA		SECTION MODULUS		RADIUS OF GYRATION		PLASTIC MODULUS	
		NOMINAL	ACTUAL						I <sub>x</sub>	I <sub>y</sub>	Z <sub>x</sub>	Z <sub>y</sub>	i <sub>x</sub>	i <sub>y</sub>	S <sub>x</sub>	S <sub>y</sub>
ASTM A500	ASTM A500M	mm	in	mm	in	kg/m	kg/6m	cm <sup>2</sup>	cm <sup>4</sup>	cm <sup>4</sup>	cm <sup>3</sup>	cm <sup>3</sup>	cm	cm	cm <sup>3</sup>	cm <sup>3</sup>
S38.1-1.2	S38.0-1.2	38 x 38	1 1/2 x 1 1/2	1.2	0.047	1.37	8.23	1.75	3.96	3.96	2.08	2.08	1.50	1.50	2.41	2.41
S38.1-1.6	S38.0-1.6			1.6	0.063	1.81	10.88	2.31	5.08	5.08	2.67	2.67	1.48	1.48	3.14	3.14
S38.1-2.3	S38.0-2.3			2.3	0.091	2.54	15.26	3.24	6.85	6.85	3.61	3.61	1.45	1.45	4.32	4.32
S38.1-3.0	S38.0-3.0			3.0	0.118	3.23	19.41	4.12	8.38	8.38	4.41	4.41	1.43	1.43	5.38	5.38
S38.1-3.2	S38.0-3.2			3.2	0.126	3.41	20.48	4.35	8.78	8.78	4.62	4.62	1.42	1.42	5.67	5.67
S50.8-1.6	S50.0-1.6	50 x 50	2 x 2	1.6	0.063	2.42	14.51	3.08	12.00	12.00	4.79	4.79	1.97	1.97	5.57	5.57
S50.8-2.3	S50.0-2.3			2.3	0.091	3.41	20.44	4.34	16.40	16.40	6.56	6.56	1.94	1.94	7.74	7.74
S50.8-3.0	S50.0-3.0			3.0	0.118	4.25	25.48	5.41	19.50	19.50	7.79	7.79	1.90	1.90	9.39	9.39
S50.8-3.2	S50.0-3.2			3.2	0.126	4.54	27.26	5.79	21.35	21.35	8.41	8.41	1.92	1.92	10.2	10.2
S50.8-4.0	S50.0-4.0			4.0	0.157	5.46	32.73	6.95	23.70	23.70	9.49	9.49	1.85	1.85	11.7	11.7
S50.8-4.5	S50.0-4.5			4.5	0.177	6.02	36.13	7.67	25.50	25.50	10.20	10.20	1.82	1.82	12.8	12.8
S63.5-2.3	S65.0-2.3	65 x 65	2 1/2 x 2 1/2	2.3	0.091	4.42	26.52	5.63	36.40	36.40	11.20	11.20	2.54	2.54	13.1	13.1
S63.5-3.0	S65.0-3.0			3.0	0.118	5.66	33.96	7.21	45.40	45.40	14.00	14.00	2.51	2.51	16.6	16.6
S63.5-3.2	S65.0-3.2			3.2	0.126	5.82	34.95	7.42	44.12	44.12	13.88	13.88	2.44	2.44	16.6	16.6
S63.5-4.0	S65.0-4.0			4.0	0.157	7.34	44.04	9.35	56.60	56.60	17.40	17.40	2.46	2.46	21.0	21.0
S63.5-4.5	S65.0-4.5			4.5	0.177	8.14	48.84	10.37	61.60	61.60	18.90	18.90	2.44	2.44	23.1	23.1
S63.5-6.0	S65.0-6.0			6.0	0.236	10.39	62.31	13.23	73.90	73.90	22.70	22.70	2.36	2.36	28.5	28.5
S76.2-2.3	S75.0-2.3	75 x 75	3 x 3	2.3	0.091	5.14	30.85	6.55	57.10	57.10	15.20	15.20	2.95	2.95	17.7	17.7
S76.2-3.0	S75.0-3.0			3.0	0.118	6.60	39.61	8.41	71.60	71.60	19.10	19.10	2.92	2.92	22.5	22.5
S76.2-3.2	S75.0-3.2			3.2	0.126	7.09	42.54	9.03	79.08	79.08	20.65	20.65	2.95	2.95	24.4	24.4

# SQUARE HOLLOW SECTIONS

ASTM A500 / A500M GRADES A & B / MANUFACTURER'S STANDARD

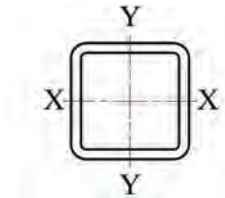

TUBE REF. NO. (TRN)		SIZE		WALL THICKNESS		CALCULATED WEIGHT		AREA	MOMENT OF INERTIA		SECTION MODULUS		RADIUS OF GYRATION		PLASTIC MODULUS	
		NOMINAL	ACTUAL						I <sub>x</sub>	I <sub>y</sub>	Z <sub>x</sub>	Z <sub>y</sub>	i <sub>x</sub>	i <sub>y</sub>	S <sub>x</sub>	S <sub>y</sub>
ASTM A500	ASTM A500M	mm	in	mm	in	kg/m	kg/6m	cm <sup>2</sup>	cm <sup>4</sup>	cm <sup>4</sup>	cm <sup>3</sup>	cm <sup>3</sup>	cm	cm	cm <sup>3</sup>	cm <sup>3</sup>
S76.2-4.0	S75.0-4.0	75 x 75	3 x 3	4.0	0.157	8.60	51.57	10.95	90.20	90.20	24.00	24.00	2.87	2.87	28.8	28.8
S76.2-4.5	S75.0-4.5			4.5	0.177	9.55	57.32	12.17	98.60	98.60	26.30	26.30	2.85	2.85	31.7	31.7
S76.2-5.0	S75.0-5.0			5.0	0.197	10.49	62.93	13.36	106.00	106.00	28.40	28.40	2.82	2.82	34.5	34.5
S76.2-6.0	S75.0-6.0			6.0	0.236	12.27	73.62	15.63	120.00	120.00	32.00	32.00	2.77	2.77	39.6	39.6
S88.9-3.0	S90.0-3.0	90 x 90	3 1/2 x 3 1/2	3.0	0.118	8.01	48.09	10.21	127.00	127.00	28.30	28.30	3.53	3.53	33.0	33.0
S88.9-3.2	S90.0-3.2			3.2	0.126	8.36	50.14	10.65	128.62	128.62	28.84	28.84	3.48	3.48	33.9	33.9
S88.9-4.0	S90.0-4.0			4.0	0.157	10.48	62.88	13.35	162.00	162.00	36.00	36.00	3.48	3.48	42.6	42.6
S88.9-4.5	S90.0-4.5			4.5	0.177	11.67	70.04	14.87	178.00	178.00	39.50	39.50	3.46	3.46	47.1	47.1
S88.9-5.0	S90.0-5.0			5.0	0.197	12.84	77.06	16.36	193.00	193.00	42.90	42.90	3.43	3.43	51.4	51.4
S88.9-6.0	S90.0-6.0			6.0	0.236	15.10	90.57	19.23	220.00	220.00	49.00	49.00	3.39	3.39	59.5	59.5
S101.6-3.0	S100.0-3.0	100 x 100	4 x 4	3.0	0.118	8.96	53.74	11.41	177.00	177.00	35.40	35.40	3.94	3.94	41.2	41.2
S101.6-3.2	S100.0-3.2			3.2	0.126	9.62	57.74	12.26	195.63	195.63	38.51	38.51	3.99	3.99	44.9	44.9
S101.6-4.0	S100.0-4.0			4.0	0.157	11.74	70.41	14.95	226.00	226.00	45.30	45.30	3.89	3.89	53.3	53.3
S101.6-4.5	S100.0-4.5			4.5	0.177	13.09	78.52	16.67	249.00	249.00	49.90	49.90	3.87	3.87	59.0	59.0
S101.6-5.0	S100.0-5.0			5.0	0.197	14.41	86.48	18.36	271.00	271.00	54.20	54.20	3.84	3.84	64.6	64.6
S101.6-6.0	S100.0-6.0			6.0	0.236	16.98	101.88	21.63	311.00	311.00	62.30	62.30	3.79	3.79	75.1	75.1
S101.6-9.0	S100.0-9.0			9.0	0.354	23.55	141.30	30.00	391.00	391.00	78.10	78.10	3.61	3.61	98.6	98.6



# SQUARE HOLLOW SECTIONS

ASTM A500 / A500M GRADES A & B / MANUFACTURER'S STANDARD

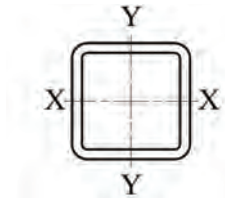

TUBE REF. NO. (TRN)		SIZE		WALL THICKNESS		CALCULATED WEIGHT		AREA	MOMENT OF INERTIA		SECTION MODULUS		RADIUS OF GYRATION		PLASTIC MODULUS	
		NOMINAL	ACTUAL						I <sub>x</sub>	I <sub>y</sub>	Z <sub>x</sub>	Z <sub>y</sub>	i <sub>x</sub>	i <sub>y</sub>	S <sub>x</sub>	S <sub>y</sub>
ASTM A500	ASTM A500M	mm	in	mm	in	kg/m	kg/6m	cm <sup>2</sup>	cm <sup>4</sup>	cm <sup>4</sup>	cm <sup>3</sup>	cm <sup>3</sup>	cm	cm	cm <sup>3</sup>	cm <sup>3</sup>
S127.0-4.5	S125.0-4.5	125 x 125	5 x 5	4.5	0.177	16.62	99.71	21.17	506.00	506.00	80.90	80.90	4.89	4.89	94.8	94.8
S127.0-5.0	S125.0-5.0			5.0	0.197	18.34	110.03	23.36	553.00	553.00	88.40	88.40	4.86	4.86	104.0	104.0
S127.0-6.0	S125.0-6.0			6.0	0.236	21.69	130.14	27.63	641.00	641.00	103.00	103.00	4.82	4.82	122.0	122.0
S127.0-9.0	S125.0-9.0			9.0	0.354	30.62	183.69	39.00	838.00	838.00	134.00	134.00	4.64	4.64	165.0	165.0
S152.4-4.5	S150.0-4.5	150 x 150	6 x 6	4.5	0.177	20.15	120.91	25.67	896.00	896.00	120.00	120.00	5.91	5.91	139.0	139.0
S152.4-5.0	S150.0-5.0			5.0	0.197	22.26	133.58	28.36	982.00	982.00	131.00	131.00	5.89	5.89	153.0	153.0
S152.4-6.0	S150.0-6.0			6.0	0.236	26.40	158.40	33.63	1146.00	1146.00	153.00	153.00	5.84	5.84	180.0	180.0
S152.4-9.0	S150.0-9.0			9.0	0.354	37.68	226.08	48.00	1540.00	1540.00	205.00	205.00	5.66	5.66	248.0	248.0
S177.8-4.5	S175.0-4.5	175 x 175	7 x 7	4.5	0.177	23.70	142.21	30.19	1386.05	1386.05	158.30	158.30	6.78	6.78	191.7	191.7
S177.8-6.0	S175.0-6.0			6.0	0.236	31.10	186.58	39.61	1798.12	1798.12	204.84	204.84	6.73	6.73	242.5	242.5
S177.8-9.0	S175.0-9.0			9.0	0.354	45.28	271.66	57.68	2559.82	2559.82	293.33	293.33	6.65	6.65	350.7	350.7
S203.2-4.5	S200.0-4.5	200 x 200	8 x 8	4.5	0.177	27.22	163.30	34.67	2191.60	2191.60	219.20	219.20	7.95	7.95	252.9	252.9
S203.2-6.0	S200.0-6.0			6.0	0.236	35.82	214.92	45.63	2832.90	2832.90	283.30	283.30	7.88	7.88	329.7	329.7
S203.2-9.0	S200.0-9.0			9.0	0.354	52.34	314.06	66.68	3988.80	3988.80	398.90	398.90	7.73	7.73	472.4	472.4
S254.0-6.0	S250.0-6.0	250 x 250	10 x 10	6.0	0.236	45.24	271.44	57.63	5672.20	5672.20	453.80	453.80	9.92	9.92	524.5	524.5
S254.0-9.0	S250.0-9.0			9.0	0.354	66.47	398.84	84.68	8093.60	8093.60	647.50	647.50	9.78	9.78	758.8	758.8

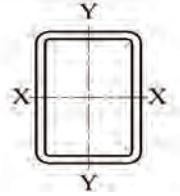

# RECTANGULAR HOLLOW SECTIONS

ASTM A-500/ A500M GRADES A & B / MANUFACTURER'S STANDARD

TUBE REF. NO. (TRN)		SIZE		WALL THICKNESS		CALCULATED WEIGHT		AREA	MOMENT OF INERTIA		SECTION MODULUS		RADIUS OF GYRATION		PLASTIC MODULUS	
		NOMINAL	ACTUAL						I <sub>x</sub>	I <sub>y</sub>	Z <sub>x</sub>	Z <sub>y</sub>	i <sub>x</sub>	i <sub>y</sub>	S <sub>x</sub>	S <sub>y</sub>
ASTM A500	ASTM A500M	mm	in	mm	in	kg/m	kg/6m	cm <sup>2</sup>	cm <sup>4</sup>	cm <sup>4</sup>	cm <sup>3</sup>	cm <sup>3</sup>	cm	cm	cm <sup>3</sup>	cm <sup>3</sup>
R19.1x9.5-1.0	R19.0x9.0-1.0	19 x 9	3/4 x 3/8	1.0	0.039	0.39	2.36	0.50	0.22	0.07	0.23	0.15	0.66	0.38	0.30	0.18
R19.1x9.5-1.2	R19.0x9.0-1.2			1.2	0.047	0.46	2.77	0.59	0.25	0.08	0.27	0.17	0.66	0.37	0.35	0.21
R19.1x9.5-1.6	R19.0x9.0-1.6			1.6	0.063	0.59	3.51	0.75	0.32	0.10	0.33	0.20	0.65	0.36	0.44	0.26
R25.4x12.7-1.0	R25.0x12.0-1.0	25 x 12	1 x 1/2	1.0	0.039	0.56	3.34	0.71	0.57	0.19	0.45	0.30	0.90	0.52	0.57	0.35
R25.4x12.7-1.2	R25.0x12.0-1.2			1.2	0.047	0.66	3.95	0.84	0.67	0.22	0.53	0.34	0.89	0.51	0.67	0.40
R25.4x12.7-1.6	R25.0x12.0-1.6			1.6	0.063	0.86	5.17	1.10	0.84	0.27	0.66	0.42	0.87	0.49	0.85	0.51
R31.7x15.9-1.0	R32.0x16.0-1.0	32 x 16	1 1/4 x 5/8	1.0	0.039	0.71	4.25	0.90	1.18	0.39	0.74	0.49	1.14	0.66	0.66	0.46
R31.7x15.9-1.2	R32.0x16.0-1.2			1.2	0.047	0.84	5.04	1.07	1.39	0.46	0.88	2.80	1.14	0.65	0.78	0.54
R31.7x15.9-1.6	R32.0x16.0-1.6			1.6	0.063	1.10	6.59	1.40	1.78	0.57	1.12	3.59	1.13	0.64	1.01	0.70
R38.1x19.1-1.0	R38.0x19.0-1.0	38 x 19	1 1/2 x 3/4	1.0	0.039	0.86	5.17	1.10	2.08	0.70	1.09	0.73	1.38	0.80	0.76	0.58
R38.1x19.1-1.2	R38.0x19.0-1.2			1.2	0.047	1.02	6.11	1.30	2.33	0.82	1.22	0.86	1.34	0.80	0.90	0.68
R38.1x19.1-1.6	R38.0x19.0-1.6			1.6	0.063	1.33	8.01	1.70	3.06	1.01	1.61	1.06	1.34	0.77	2.08	1.26
R38.1x25.4-1.0	R38.0x25.0-1.0	38 x 25	1 1/2 x 1	1.0	0.039	0.95	5.71	1.21	2.48	1.32	1.30	1.04	1.43	1.05	1.56	1.18
R38.1x25.4-1.2	R38.0x25.0-1.2			1.2	0.047	1.13	6.81	1.45	2.93	1.56	1.54	1.23	1.42	1.04	1.85	1.40
R38.1x25.4-1.6	R38.0x25.0-1.6			1.6	0.063	1.48	8.90	1.89	3.70	1.91	1.95	1.53	1.40	1.01	2.42	1.80
R50.8x25.4-1.0	R50.0x25.0-1.0	50 x 25	2 x 1	1.0	0.039	1.15	6.90	1.46	4.99	1.70	1.97	1.34	1.85	1.08	2.41	1.49
R50.8x25.4-1.2	R50.0x25.0-1.2			1.2	0.047	1.37	8.23	1.75	5.91	2.00	2.33	1.58	1.84	1.07	2.87	1.77
R50.8x25.4-1.6	R50.0x25.0-1.6			1.6	0.063	1.79	10.74	2.28	7.29	2.44	2.91	1.95	1.79	1.03	3.69	2.25
R50.8x25.4-2.3	R50.0x25.0-2.3			2.3	0.091	2.50	15.02	3.19	9.86	3.23	3.94	2.59	1.76	1.01	5.11	3.09

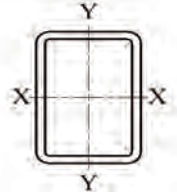

# RECTANGULAR HOLLOW SECTIONS

ASTM A-500/ A500M GRADES A & B / MANUFACTURER'S STANDARD

TUBE REF. NO. (TRN)		SIZE		WALL THICKNESS		CALCULATED WEIGHT		AREA	MOMENT OF INERTIA		SECTION MODULUS		RADIUS OF GYRATION		PLASTIC MODULUS	
		NOMINAL	ACTUAL						I <sub>x</sub>	I <sub>y</sub>	Z <sub>x</sub>	Z <sub>y</sub>	i <sub>x</sub>	i <sub>y</sub>	S <sub>x</sub>	S <sub>y</sub>
ASTM A500	ASTM A500M	mm	in	mm	in	kg/m	kg/6m	cm <sup>2</sup>	cm <sup>4</sup>	cm <sup>4</sup>	cm <sup>3</sup>	cm <sup>3</sup>	cm	cm	cm <sup>3</sup>	cm <sup>3</sup>
R50.8x25.4-3.0	R50.0x25.0-3.0	50 x 25	2 x 1	3.0	0.118	3.19	19.12	4.06	12.10	3.89	4.84	3.11	1.73	0.98	6.43	3.84
R50.8x25.4-3.2	R50.0x25.0-3.2			3.2	0.126	3.41	20.48	4.35	13.28	4.25	5.23	3.34	1.75	0.99	6.77	4.06
R63.5x38.1-1.6	R65.0x38.0-1.6	65 x 38	2 1/2 x 1 1/2	1.6	0.063	2.49	14.93	3.17	18.30	7.94	5.63	4.18	2.40	1.58	6.91	4.75
R63.5x38.1-2.3	R65.0x38.0-2.3			2.3	0.091	3.52	21.10	4.48	25.20	10.80	7.74	5.69	2.37	1.55	9.68	6.62
R63.5x38.1-3.0	R65.0x38.0-3.0			3.0	0.118	4.15	24.92	5.29	29.80	12.80	9.18	6.75	2.31	1.51	12.30	8.36
R63.5x38.1-3.2	R65.0x38.0-3.2			3.2	0.126	4.65	27.88	5.92	31.30	13.40	9.63	7.06	2.30	1.51	13.00	8.84
R76.2x38.1-1.6	R75.0x38.0-1.6	75 x 38	3 x 1 1/2	1.6	0.063	2.71	16.25	3.45	25.30	8.85	6.76	4.66	2.71	1.60	8.59	5.34
R76.2x38.1-1.9	R75.0x38.0-1.9			1.9	0.075	3.19	19.12	4.06	29.40	10.20	7.85	5.39	2.69	1.59	10.10	6.26
R76.2x38.1-2.3	R75.0x38.0-2.3			2.3	0.091	3.81	22.84	4.85	34.60	12.00	9.23	6.30	2.67	1.57	12.10	7.44
R76.2x38.1-3.0	R75.0x38.0-3.0			3.0	0.118	4.86	29.15	6.19	42.80	14.70	11.40	7.72	2.63	1.54	15.30	9.41
R76.2x38.1-3.2	R75.0x38.0-3.2			3.2	0.126	5.15	30.90	6.56	45.00	15.40	12.00	8.09	2.62	1.53	16.30	9.95
R76.2x50.8-1.9	R75.0x50.0-1.9	75 x 50	3 x 2	1.9	0.075	3.54	21.24	4.51	35.50	19.10	9.48	7.62	2.81	2.05	11.80	8.88
R76.2x50.8-2.3	R75.0x50.0-2.3			2.3	0.091	4.24	25.43	5.40	41.90	22.40	11.20	8.96	2.79	2.04	14.10	10.60
R76.2x50.8-3.0	R75.0x50.0-3.0			3.0	0.118	5.42	32.55	6.91	52.20	27.80	13.90	11.10	2.75	2.00	17.90	13.50
R76.2x50.8-3.2	R75.0x50.0-3.2			3.2	0.126	5.82	34.95	7.42	57.44	30.51	15.08	12.01	2.79	2.03	18.52	14.01
R76.2x50.8-4.0	R75.0x50.0-4.0			4.0	0.157	7.03	42.15	8.95	65.00	34.30	17.30	13.70	2.69	1.96	23.20	17.30
R76.2x50.8-4.5	R75.0x50.0-4.5			4.5	0.177	7.79	46.72	9.92	70.60	37.20	18.80	14.90	2.67	1.94	25.70	19.10
R76.2x50.8-6.0	R75.0x50.0-6.0			6.0	0.236	9.91	59.49	12.63	84.40	44.10	22.50	17.60	2.58	1.87	32.60	24.10



# RECTANGULAR HOLLOW SECTIONS

ASTM A-500/ A500M GRADES A & B / MANUFACTURER'S STANDARD

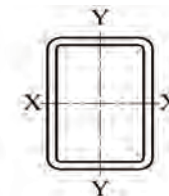

TUBE REF. NO. (TRN)		SIZE		WALL THICKNESS		CALCULATED WEIGHT		AREA	MOMENT OF INERTIA		SECTION MODULUS		RADIUS OF GYRATION		PLASTIC MODULUS	
		NOMINAL	ACTUAL						I <sub>x</sub>	I <sub>y</sub>	Z <sub>x</sub>	Z <sub>y</sub>	i <sub>x</sub>	i <sub>y</sub>	S <sub>x</sub>	S <sub>y</sub>
ASTM A500	ASTM A500M	mm	in	mm	in	kg/m	kg/6m	cm <sup>2</sup>	cm <sup>4</sup>	cm <sup>4</sup>	cm <sup>3</sup>	cm <sup>3</sup>	cm	cm	cm <sup>3</sup>	cm <sup>3</sup>
R101.6x50.8-1.9	R100.0x50.0-1.9	100 x 50	4 x 2	1.9	0.075	4.29	25.72	5.46	71.60	24.50	14.30	9.80	3.62	2.12	18.10	11.20
R101.6x50.8-2.3	R100.0x50.0-2.3			2.3	0.091	5.14	30.85	6.55	84.80	29.00	17.00	11.60	3.60	2.10	21.70	13.30
R101.6x50.8-3.0	R100.0x50.0-3.0			3.0	0.118	6.60	39.61	8.41	106.00	36.10	21.30	14.40	3.56	2.07	27.80	17.00
R101.6x50.8-3.2	R100.0x50.0-3.2			3.2	0.126	7.09	42.54	9.03	117.38	39.71	23.11	15.63	3.61	2.10	29.01	17.86
R101.6x50.8-4.0	R100.0x50.0-4.0			4.0	0.157	8.60	51.57	10.95	134.00	44.90	26.80	18.00	3.50	2.03	36.10	21.90
R101.6x50.8-4.5	R100.0x50.0-4.5			4.5	0.177	9.55	57.32	12.17	147.00	48.90	29.30	19.50	3.47	2.00	40.10	24.30
R101.6x50.8-5.0	R100.0x50.0-5.0			5.0	0.197	10.49	62.93	13.36	158.00	52.50	31.60	21.00	3.44	1.98	44.00	26.50
R101.6x50.8-6.0	R100.0x50.0-6.0			6.0	0.236	12.27	73.62	15.63	179.00	58.70	35.70	23.50	3.38	1.94	51.40	30.70
R101.6x76.2-3.0	R100.0x75.0-3.0	100 x 75	4 x 3	3.0	0.118	7.78	46.68	9.91	142.00	91.10	28.40	24.30	3.78	3.03	35.10	28.70
R101.6x76.2-3.2	R100.0x75.0-3.2			3.2	0.126	8.36	50.14	10.65	156.50	100.31	30.81	26.38	3.84	3.07	36.87	30.32
R101.6x76.2-4.0	R100.0x75.0-4.0			4.0	0.157	10.17	60.99	12.95	180.00	115.00	36.00	30.80	3.73	2.99	45.70	37.40
R101.6x76.2-4.5	R100.0x75.0-4.5			4.5	0.177	11.32	67.92	14.42	198.00	127.00	39.60	33.70	3.71	2.96	50.90	41.50
R101.6x76.2-5.0	R100.0x75.0-5.0			5.0	0.197	12.45	74.70	15.86	215.00	137.00	42.90	36.50	3.68	2.94	55.90	45.60
R101.6x76.2-6.0	R100.0x75.0-6.0			6.0	0.236	14.62	87.75	18.63	245.00	156.00	49.00	41.60	3.63	2.89	65.50	53.30
R127.0x50.8-3.0	R125.0x50.0-3.0	125 x 50	5 x 2	3.0	0.118	7.78	46.68	9.91	187.00	44.40	29.90	17.70	4.34	2.12	39.50	20.50
R127.0x50.8-3.2	R125.0x50.0-3.2			3.2	0.126	8.36	50.14	10.65	206.45	48.70	32.45	19.17	4.39	2.14	41.46	21.63
R127.0x50.8-4.0	R125.0x50.0-4.0			4.0	0.157	10.17	60.99	12.95	238.00	55.60	38.00	22.20	4.28	2.07	51.60	26.50
R127.0x50.8-4.5	R125.0x50.0-4.5			4.5	0.177	11.32	67.92	14.42	261.00	60.60	41.70	24.20	4.25	2.05	57.40	29.40
R127.0x50.8-5.0	R125.0x50.0-5.0			5.0	0.197	12.45	74.70	15.86	282.00	65.20	45.20	26.10	4.22	2.03	63.10	32.10
R127.0x50.8-6.0	R125.0x50.0-6.0			6.0	0.236	14.62	87.75	18.63	322.00	73.30	51.50	29.30	4.16	1.98	74.00	37.30

# RECTANGULAR HOLLOW SECTIONS

ASTM A-500/ A500M GRADES A & B / MANUFACTURER'S STANDARD

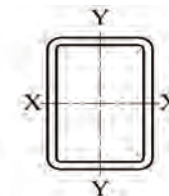

TUBE REF. NO. (TRN)		SIZE		WALL THICKNESS		CALCULATED WEIGHT		AREA	MOMENT OF INERTIA		SECTION MODULUS		RADIUS OF GYRATION		PLASTIC MODULUS	
		NOMINAL	ACTUAL						I <sub>x</sub>	I <sub>y</sub>	Z <sub>x</sub>	Z <sub>y</sub>	i <sub>x</sub>	i <sub>y</sub>	S <sub>x</sub>	S <sub>y</sub>
ASTM A500	ASTM A500M	mm	in	mm	in	kg/m	kg/6m	cm <sup>2</sup>	cm <sup>4</sup>	cm <sup>4</sup>	cm <sup>3</sup>	cm <sup>3</sup>	cm	cm	cm <sup>3</sup>	cm <sup>3</sup>
R127.0x76.2-3.0	R125.0x75.0-3.0	125 x 75	5 x 3	3.0	0.118	8.96	53.74	11.41	243.00	111.00	38.90	29.50	4.61	3.12	48.70	34.10
R127.0x76.2-3.2	R125.0x75.0-3.2			3.2	0.126	9.62	57.74	12.26	268.05	121.96	42.28	31.95	4.67	3.15	51.46	36.22
R127.0x76.2-4.0	R125.0x75.0-4.0			4.0	0.157	11.74	70.41	14.95	311.00	141.00	49.70	37.50	4.56	3.07	63.70	44.50
R127.0x76.2-4.5	R125.0x75.0-4.5			4.5	0.177	13.09	78.52	16.67	342.00	155.00	54.80	41.20	4.53	3.04	70.90	49.50
R127.0x76.2-5.0	R125.0x75.0-5.0			5.0	0.197	14.41	86.48	18.36	373.00	168.00	59.60	44.70	4.50	3.02	78.10	54.30
R127.0x76.2-6.0	R125.0x75.0-6.0			6.0	0.236	16.98	101.88	21.63	428.00	192.00	68.50	51.10	4.45	2.98	91.90	63.70
R127.0x76.2-9.0	R125.0x75.0-9.0			9.0	0.354	24.52	147.09	31.23	626.00	269.00	98.50	70.60	4.47	2.94	126.30	86.50
R152.4x50.8-3.0	R150.0x50.0-3.0	150 x 50	6 x 2	3.0	0.118	8.96	53.74	11.41	299.00	52.60	39.80	21.10	5.12	2.15	53.20	24.10
R152.4x50.8-3.2	R150.0x50.0-3.2			3.2	0.126	9.62	57.74	12.26	329.66	57.86	43.26	22.78	5.18	2.18	56.04	25.56
R152.4x50.8-4.0	R150.0x50.0-4.0			4.0	0.157	11.74	70.41	14.95	381.00	66.20	50.90	26.50	5.05	2.10	69.50	31.10
R152.4x50.8-4.5	R150.0x50.0-4.5			4.5	0.177	13.09	78.52	16.67	420.00	72.20	56.00	28.90	5.02	2.08	77.50	34.50
R152.4x50.8-5.0	R150.0x50.0-5.0			5.0	0.197	14.41	86.48	18.36	456.00	77.90	60.80	31.10	4.99	2.06	85.30	37.80
R152.4x50.8-6.0	R150.0x50.0-6.0			6.0	0.236	16.98	101.88	21.63	523.00	87.90	69.80	35.20	4.92	2.02	100.00	43.90
R152.4x76.2-3.2	R150.0x75.0-3.2	150 x 75	6 x 3	3.2	0.126	10.79	64.72	13.74	420.39	143.18	54.90	37.69	5.51	3.23	65.38	40.48
R152.4x76.2-4.0	R150.0x75.0-4.0			4.0	0.157	13.31	79.83	16.95	488.00	166.00	65.10	44.20	5.37	3.13	84.10	51.60
R152.4x76.2-4.5	R150.0x75.0-4.5			4.5	0.177	14.85	89.11	18.92	539.00	183.00	71.90	48.70	5.34	3.11	93.80	57.40
R152.4x76.2-5.0	R150.0x75.0-5.0			5.0	0.197	16.38	98.25	20.86	588.00	198.00	78.40	52.90	5.31	3.08	103.00	63.10
R152.4x76.2-6.0	R150.0x75.0-6.0			6.0	0.236	19.33	116.01	24.63	679.00	228.00	90.50	60.70	5.25	3.04	122.00	74.00
R152.4x76.2-9.0	R150.0x75.0-9.0			9.0	0.354	27.61	165.65	35.17	905.00	297.00	121.00	79.20	5.07	2.91	172.00	105.00

# RECTANGULAR HOLLOW SECTIONS

ASTM A-500/ A500M GRADES A & B / MANUFACTURER'S STANDARD

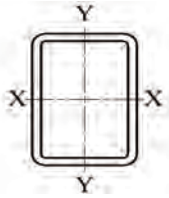

TUBE REF. NO. (TRN)		SIZE		WALL THICKNESS		CALCULATED WEIGHT		AREA	MOMENT OF INERTIA		SECTION MODULUS		RADIUS OF GYRATION		PLASTIC MODULUS	
		NOMINAL	ACTUAL						I <sub>x</sub>	I <sub>y</sub>	Z <sub>x</sub>	Z <sub>y</sub>	i <sub>x</sub>	i <sub>y</sub>	S <sub>x</sub>	S <sub>y</sub>
ASTM A500	ASTM A500M	mm	in	mm	in	kg/m	kg/6m	cm <sup>2</sup>	cm <sup>4</sup>	cm <sup>4</sup>	cm <sup>3</sup>	cm <sup>3</sup>	cm	cm	cm <sup>3</sup>	cm <sup>3</sup>
R152.4x101.6-4.0	R150.0x100.0-4.0	150 x 100	6 x 4	4.0	0.157	14.88	89.25	18.95	595.00	319.00	79.30	63.70	5.60	4.10	98.70	74.50
R152.4x101.6-4.5	R150.0x100.0-4.5			4.5	0.177	16.62	99.71	21.17	658.00	352.00	87.70	70.40	5.58	4.08	110.00	83.10
R152.4x101.6-5.0	R150.0x100.0-5.0			5.0	0.197	18.34	110.03	23.36	719.00	384.00	95.90	76.80	5.55	4.05	122.00	91.50
R152.4x101.6-6.0	R150.0x100.0-6.0			6.0	0.236	21.69	130.14	27.63	835.00	444.00	111.10	88.80	5.50	4.01	144.00	108.00
R152.4x101.6-9.0	R150.0x100.0-9.0			9.0	0.354	31.14	186.85	39.67	1129.00	595.00	150.50	119.00	5.33	3.87	190.00	143.00
R177.8x101.6-4.5	R175.0x100.0-4.5	175 x 100	7 x 4	4.5	0.177	18.43	110.61	23.48	1015.60	424.14	114.38	83.57	6.58	4.24	134.87	91.28
R177.8x101.6-6.0	R175.0x100.0-6.0			6.0	0.236	24.26	145.55	30.90	1298.64	536.94	146.01	105.53	6.45	4.17	177.31	119.30
R177.8x101.6-9.0	R175.0x100.0-9.0			9.0	0.354	34.69	208.15	44.19	1694.06	686.78	193.37	137.65	6.20	3.94	244.82	163.22
R177.8x127.0-4.5	R175.0x125.0-4.5	175 x 125	7 x 5	4.5	0.177	20.46	122.76	26.06	1194.58	707.59	134.37	111.76	6.73	5.21	159.94	126.84
R177.8x127.0-6.0	R175.0x125.0-6.0			6.0	0.236	26.74	160.44	34.06	1502.60	899.06	170.43	141.26	6.68	5.13	196.64	155.51
R177.8x127.0-9.0	R175.0x125.0-9.0			9.0	0.354	38.19	229.12	48.65	1985.42	1157.12	226.14	185.17	6.38	4.88	280.05	220.24
R203.2x101.6-4.5	R200.0x100.0-4.5	200 x 100	8 x 4	4.5	0.177	20.15	120.91	25.67	1331.00	455.00	133.00	90.90	7.20	4.21	170.00	105.00
R203.2x101.6-5.0	R200.0x100.0-5.0			5.0	0.197	22.26	133.58	28.36	1459.00	497.00	146.00	99.40	7.17	4.19	188.00	115.00
R203.2x101.6-6.0	R200.0x100.0-6.0			6.0	0.236	26.40	158.40	33.63	1703.00	577.00	170.00	115.00	7.12	4.14	222.00	136.00
R203.2x101.6-9.0	R200.0x100.0-9.0			9.0	0.354	37.68	226.08	48.00	2280.00	764.00	228.00	153.00	6.89	3.99	293.00	180.00
R203.2x152.4-4.5	R200.0x150.0-4.5	200 x 150	8 x 6	4.5	0.177	23.68	142.10	30.17	1761.60	1134.60	176.20	151.30	7.64	6.13	208.90	171.80
R203.2x152.4-6.0	R200.0x150.0-6.0			6.0	0.236	31.11	186.66	39.63	2268.10	1457.20	226.80	194.30	7.56	6.06	271.50	223.10
R203.2x152.4-9.0	R200.0x150.0-9.0			9.0	0.354	45.28	271.66	57.68	3167.30	2024.90	316.70	270.00	7.41	5.93	386.40	316.90
R254.0x152.4-6.0	R250.0x150.0-6.0	250 x 150	10 x 6	6.0	0.236	35.82	214.92	45.63	1768.40	3885.70	310.90	235.80	9.23	6.23	378.10	266.30
R254.0x152.4-9.0	R250.0x150.0-9.0			9.0	0.354	52.34	314.06	66.68	2472.80	5478.70	438.30	329.70	9.06	6.09	541.90	380.40
R304.8x203.2-6.0	R300.0x200.0-6.0	300 x 200	12 x 8	6.0	0.236	45.24	271.44	57.63	7370.50	3962.30	491.40	396.20	11.31	8.29	587.80	446.10
R304.8x203.2-9.0	R300.0x200.0-9.0			9.0	0.354	66.47	398.84	84.68	10529.50	5631.61	702.00	563.20	11.15	8.16	850.80	644.30

NOTE: Sizes with shaded are uncommon size



# COLD FORMED SQUARE HOLLOW SECTIONS

MS EN 10219 / BS EN 10219 / MANUFACTURER'S STANDARD

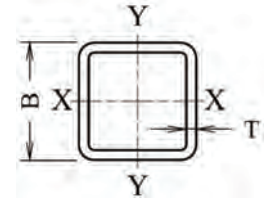

Tube Ref. No.(TRN)	Specified Dimension		Mass per unit length	Cross Sectional Area	Second Moment of Area	Radius of Gyration	Elastic Section Modulus	Plastic Section Modulus	Torsional Inertia Constant	Torsional Modulus Constant	Superficial area per meter length	Nominal length per tonne	Ratio for Local Buckling
	Size	Thickness											Flange
	B X B	T	M	A	I	i	$W_{el}$	$W_{pl}$	$L_t$	$C_t$	$A_s$		B/T
	mm	mm	Kg/m	cm <sup>2</sup>	cm <sup>4</sup>	cm	cm <sup>3</sup>	cm <sup>3</sup>	cm <sup>4</sup>	cm <sup>3</sup>	m <sup>2</sup> /m	m	
S 20.0-1.0	20 x 20	1.00	0.58	0.73	0.43	0.77	0.43	0.52	0.70	0.65	0.077	1735.0	15.0
S 20.0-1.2		1.20	0.68	0.87	0.50	0.76	0.50	0.60	0.82	0.75	0.076	1472.2	11.7
S 20.0-1.5		1.50	0.83	1.05	0.58	0.74	0.58	0.72	0.98	0.88	0.075	1210.9	8.3
S 25.0-1.0	25 x 25	1.00	0.73	0.93	0.88	0.97	0.71	0.83	1.41	1.06	0.097	1363.5	20.0
S 25.0-1.2		1.20	0.87	1.11	1.03	0.96	0.82	0.97	1.66	1.24	0.096	1152.5	15.8
S 25.0-1.5		1.50	1.06	1.35	1.22	0.95	0.97	1.17	2.01	1.47	0.095	942.2	11.7
S 25.0-2.0		2.00	1.36	1.74	1.48	0.92	1.19	1.47	2.53	1.80	0.093	733.4	7.5
S 25.0-2.3		2.30	1.53	1.95	1.61	0.91	1.29	1.62	2.80	1.97	0.092	652.5	5.9
S 25.0-2.5		2.50	1.64	2.09	1.69	0.90	1.35	1.71	2.97	2.07	0.091	609.8	5.0
S 25.0-3.0		3.00	1.89	2.41	1.84	0.87	1.47	1.91	3.33	2.27	0.090	529.0	3.3
S 32.0-1.2	32 x 32	1.20	1.13	1.44	2.25	1.25	1.41	1.65	3.58	2.11	0.124	883.8	21.7
S 32.0-1.5		1.50	1.39	1.77	2.70	1.23	1.69	2.00	4.37	2.54	0.123	718.9	16.3
S 32.0-2.0		2.00	1.80	2.30	3.36	1.21	2.10	2.54	5.58	3.18	0.121	554.6	11.0
S 32.0-2.3		2.30	2.04	2.60	3.71	1.20	2.32	2.84	6.24	3.52	0.120	490.7	8.9
S 32.0-2.5		2.50	2.19	2.79	3.92	1.19	2.45	3.02	6.66	3.72	0.119	456.7	7.8
S 32.0-3.0		3.00	2.55	3.25	4.38	1.16	2.74	3.44	7.62	4.18	0.118	392.2	5.7
S 38.0-1.2	38 x 38	1.20	1.36	1.73	3.86	1.49	2.03	2.37	6.09	3.05	0.148	736.6	26.7
S 38.0-1.5		1.50	1.67	2.13	4.67	1.77	2.81	2.89	7.46	3.70	0.147	597.5	20.3
S 38.0-2.0		2.00	2.18	2.78	5.88	1.75	3.35	3.70	9.60	4.67	0.145	458.7	14.0
S 38.0-2.3		2.30	2.47	3.15	6.54	1.73	3.72	4.15	10.80	5.20	0.144	404.6	11.5
S 38.0-2.5		2.50	2.66	3.39	6.94	1.72	3.95	4.44	11.56	5.53	0.143	375.9	10.2
S 38.0-3.0		3.00	3.12	3.97	7.85	1.69	4.47	5.10	13.35	6.28	0.142	321.0	7.7

# COLD FORMED SQUARE HOLLOW SECTIONS

MS EN 10219 / BS EN 10219 / MANUFACTURER'S STANDARD

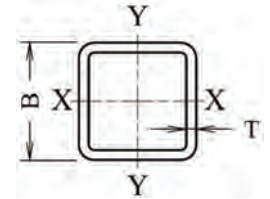

Tube Ref. No.(TRN)	Specified Dimension		Mass per unit length	Cross Sectional Area	Second Moment of Area	Radius of Gyration	Elastic Section Modulus	Plastic Section Modulus	Torsional Inertia Constant	Torsional Modulus Constant	Superficial area per meter length	Nominal length per tonne	Ratio for Local Buckling
	Size	Thickness											Flange
	B X B	T	M	A	I	i	$W_{el}$	$W_{pl}$	$L_t$	$C_t$	$A_s$		B/T
	mm	mm	Kg/m	cm <sup>2</sup>	cm <sup>4</sup>	cm	cm <sup>3</sup>	cm <sup>3</sup>	cm <sup>4</sup>	cm <sup>3</sup>	m <sup>2</sup> /m	m	
S 40.0-1.5	40 x 40	1.50	1.77	2.25	5.49	1.56	2.75	3.22	8.75	4.13	0.155	565.7	21.7
S 40.0-2.0		2.00	2.31	2.94	6.94	1.54	3.47	4.13	11.28	5.23	0.153	432.9	15.0
S 40.0-2.5		2.50	2.82	3.59	8.22	1.51	4.11	4.97	13.61	6.21	0.151	354.6	11.0
S 40.0-3.0		3.00	3.30	4.21	9.32	1.49	4.66	5.72	15.75	7.07	0.150	303.0	8.3
S 50.0-1.5	50 x 50	1.50	2.24	2.85	11.07	1.97	4.43	5.15	17.42	6.65	0.195	446.7	28.3
S 50.0-1.9		1.90	2.80	3.56	13.60	1.95	5.42	6.37	21.60	8.15	0.193	357.6	21.3
S 50.0-2.0		2.00	2.93	3.74	14.15	1.95	5.66	6.66	22.63	8.51	0.193	340.9	20.0
S 50.0-2.3		2.30	3.34	4.25	15.86	1.93	6.34	7.52	25.61	9.55	0.192	299.6	16.7
S 50.0-2.5		2.50	3.60	4.59	16.94	1.92	6.78	8.07	27.53	10.22	0.191	277.6	15.0
S 50.0-3.0		3.00	4.25	5.41	19.47	1.90	7.79	9.39	32.13	11.76	0.190	235.5	11.7
S 50.0-4.0		4.00	5.45	6.95	26.15	1.94	10.46	12.73	40.40	14.40	0.186	183.3	7.5
S 50.0-4.5		4.50	6.02	7.67	25.50	1.82	10.20	12.76	44.09	15.56	0.185	166.1	6.1
S 50.0-5.0	5.00	6.56	8.36	27.00	1.80	10.80	13.70	47.50	16.60	0.183	152.4	5.0	
S 60.0-1.5	60 x 60	1.50	2.71	3.45	19.52	2.38	6.51	7.53	30.48	9.77	0.235	369.0	35.0
S 60.0-2.0		2.00	3.56	4.54	25.14	2.35	8.38	9.79	39.79	12.59	0.233	280.8	25.0
S 60.0-2.3		2.30	4.06	5.17	28.31	2.34	9.44	11.09	45.16	14.19	0.232	246.3	21.1
S 60.0-2.5		2.50	4.39	5.59	30.34	2.33	10.11	11.93	48.66	15.22	0.231	227.9	19.0
S 60.0-3.0		3.00	5.19	6.61	35.13	2.31	11.71	13.95	57.09	17.65	0.230	192.8	15.0
S 60.0-4.0		4.00	6.71	8.55	47.07	2.35	15.69	18.85	72.60	22.00	0.226	149.0	10.0
S 60.0-4.5		4.50	7.43	9.47	47.20	2.23	15.73	19.32	79.76	23.87	0.225	134.5	8.3
S 65.0-2.0	65 x 65	2.00	3.88	4.94	32.31	2.56	9.94	11.58	50.92	14.93	0.253	258.0	27.5
S 65.0-2.3		2.30	4.42	5.63	36.45	2.54	11.21	13.13	57.86	16.86	0.252	226.2	23.3
S 65.0-2.5		2.50	4.78	6.09	39.10	2.53	12.03	14.14	62.39	18.10	0.251	209.2	21.0
S 65.0-3.0		3.00	5.66	7.21	45.42	2.51	13.97	16.57	73.35	21.05	0.250	176.7	16.7
S 65.0-4.0		4.00	7.34	9.35	56.64	2.46	17.43	21.05	93.72	26.34	0.246	136.3	11.3
S 65.0-4.5		4.50	8.14	10.37	61.59	2.44	18.95	23.10	103.14	28.70	0.245	122.9	9.4

# COLD FORMED SQUARE HOLLOW SECTIONS

MS EN 10219 / BS EN 10219 / MANUFACTURER'S STANDARD

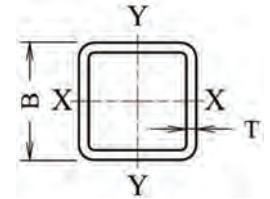

Tube Ref. No.(TRN)	Specified Dimension		Mass per unit length	Cross Sectional Area	Second Moment of Area	Radius of Gyration	Elastic Section Modulus	Plastic Section Modulus	Torsional Inertia Constant	Torsional Modulus Constant	Superficial area per meter length	Nominal length per tonne	Ratio for Local Buckling
	Size	Thickness											Flange
	B X B	T	M	A	I	i	$W_{el}$	$W_{pl}$	$L_t$	$C_t$	$A_s$	B/T	
	mm	mm	Kg/m	cm <sup>2</sup>	cm <sup>4</sup>	cm	cm <sup>3</sup>	cm <sup>3</sup>	cm <sup>4</sup>	cm <sup>3</sup>	m <sup>2</sup> /m	m	
S 65.0-5.0	65 x 65	5.00	8.91	11.36	66.10	2.41	20.34	25.03	112.03	30.88	0.243	112.2	8.0
S 65.0-6.0		6.00	10.39	13.23	73.91	2.36	22.74	28.53	128.23	34.72	0.239	96.3	5.8
S 75.0-2.3	75 x 75	2.30	5.14	6.55	57.10	2.95	15.23	17.74	89.98	22.88	0.292	194.4	27.6
S 75.0-2.5		2.50	5.56	7.09	61.38	2.94	16.37	19.12	97.13	24.60	0.291	179.7	25.0
S 75.0-3.0		3.00	6.60	8.41	71.62	2.92	19.10	22.49	114.54	28.73	0.290	151.5	20.0
S 75.0-4.0		4.00	8.59	10.95	90.19	2.87	24.05	28.76	147.32	36.28	0.286	116.4	13.8
S 75.0-4.5		4.50	9.55	12.17	98.55	2.85	26.28	31.68	162.68	39.71	0.285	104.7	11.7
S 75.0-5.0		5.00	10.48	13.36	106.33	2.82	28.35	34.46	177.35	42.92	0.283	95.4	10.0
S 75.0-6.0		6.00	12.27	15.63	120.16	2.77	32.04	39.58	204.62	48.70	0.279	81.5	7.5
S 89.0-3.0	89 x 89	3.00	7.92	10.09	122.89	3.49	27.62	32.28	194.59	41.50	0.346	126.3	24.7
S 89.0-4.0		4.00	10.35	13.19	156.25	3.44	35.11	41.58	251.87	52.87	0.342	96.6	17.3
S 89.0-4.5		4.50	11.53	14.69	171.59	3.42	38.56	45.97	279.07	58.13	0.341	86.7	14.8
S 89.0-5.0		5.00	12.68	16.16	186.07	3.39	41.81	50.18	305.30	63.11	0.339	78.8	12.8
S 89.0-6.0		6.00	14.91	18.99	212.50	3.34	47.75	58.09	354.87	72.30	0.335	67.1	9.8
S 90.0-2.3	90 x 90	2.30	6.23	7.93	100.79	3.56	22.40	25.93	157.53	33.63	0.352	160.6	34.1
S 90.0-2.5		2.50	6.74	8.59	108.55	3.56	24.12	28.00	170.26	36.23	0.351	148.3	31.0
S 90.0-3.0		3.00	8.01	10.21	127.28	3.53	28.29	33.04	201.42	42.51	0.350	124.8	25.0
S 90.0-4.0		4.00	10.48	13.35	161.92	3.48	35.98	42.58	260.80	54.17	0.346	95.4	17.5
S 90.0-4.5		4.50	11.67	14.87	177.87	3.46	39.53	47.09	289.02	59.58	0.345	85.7	15.0
S 90.0-5.0		5.00	12.84	16.36	192.93	3.43	42.87	51.41	316.26	64.70	0.343	77.9	13.0
S 90.0-6.0		6.00	15.10	19.23	220.48	3.39	48.99	59.54	367.76	74.16	0.339	66.2	10.0



# COLD FORMED SQUARE HOLLOW SECTIONS

MS EN 10219 / BS EN 10219 / MANUFACTURER'S STANDARD

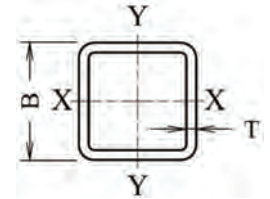

Tube Ref. No.(TRN)	Specified Dimension		Mass per unit length	Cross Sectional Area	Second Moment of Area	Radius of Gyration	Elastic Section Modulus	Plastic Section Modulus	Torsional Inertia Constant	Torsional Modulus Constant	Superficial area per meter length	Nominal length per tonne	Ratio for Local Buckling
	Size	Thickness											Flange
	B X B	T	M	A	I	i	$W_{el}$	$W_{pl}$	$L_t$	$C_t$	$A_s$		B/T
	mm	mm	Kg/m	cm <sup>2</sup>	cm <sup>4</sup>	cm	cm <sup>3</sup>	cm <sup>3</sup>	cm <sup>4</sup>	cm <sup>3</sup>	m <sup>2</sup> /m	m	
S 100.0-2.3	100 x 100	2.30	6.95	8.85	139.73	3.97	27.95	32.26	217.48	41.95	0.392	143.9	38.5
S 100.0-3.0		3.00	8.96	11.41	177.05	3.94	35.41	41.21	278.68	53.19	0.390	111.7	28.3
S 100.0-4.0		4.00	11.73	14.95	226.35	3.89	45.27	53.30	362.01	68.10	0.386	85.2	20.0
S 100.0-4.5		4.50	13.08	16.67	249.29	3.87	49.86	59.04	401.87	75.07	0.385	76.4	17.2
S 100.0-5.0		5.00	14.41	18.36	271.10	3.84	54.22	64.59	440.52	81.72	0.383	69.4	15.0
S 100.0-6.0		6.00	16.98	21.63	311.47	3.79	62.29	75.10	514.16	94.12	0.379	58.9	11.7
S 100.0-6.3		6.30	17.47	22.25	314.20	3.76	62.84	76.40	536.00	97.00	0.373	57.2	10.9
S 100.0-8.0		8.00	21.39	27.24	365.90	3.67	73.18	91.10	644.60	114.20	0.366	46.8	7.5
S 100.0-9.0		9.00	23.53	29.98	390.60	3.61	78.12	98.60	700.40	122.80	0.361	42.5	6.1
S 125.0-3.0	125 x 125	3.00	11.31	14.41	354.50	4.96	56.72	65.56	552.66	85.14	0.490	88.4	36.7
S 125.0-4.0		4.00	14.87	18.95	457.23	4.91	73.16	85.33	721.99	109.92	0.486	67.2	26.3
S 125.0-4.5		4.50	16.62	21.17	505.83	4.89	80.93	94.84	803.85	121.67	0.485	60.2	22.8
S 125.0-5.0		5.00	18.33	23.36	552.62	4.86	88.42	104.10	883.82	133.01	0.483	54.5	20.0
S 125.0-6.0		6.00	21.69	27.63	640.89	4.82	102.54	121.87	1038.10	154.49	0.479	46.1	15.8
S 125.0-6.3		6.30	22.41	28.55	652.60	4.78	104.42	124.90	1086.50	160.10	0.473	44.6	14.8
S 125.0-8.0		8.00	27.67	35.24	775.30	4.69	124.05	151.00	1325.40	191.70	0.466	36.1	10.6
S 125.0-9.0		9.00	30.60	38.98	837.80	4.64	134.05	164.90	1454.10	208.20	0.461	32.7	8.9
S 150.0-4.0	150 x 150	4.00	18.01	22.95	807.82	5.93	107.71	124.87	1264.76	161.73	0.586	55.5	32.5
S 150.0-4.5		4.50	20.15	25.67	896.30	5.91	119.51	139.08	1410.79	179.51	0.585	49.6	28.3
S 150.0-5.0		5.00	22.26	28.36	982.12	5.89	130.95	152.98	1554.13	196.79	0.583	44.9	25.0
S 150.0-6.0		6.00	26.40	33.63	1145.91	5.84	152.79	179.88	1832.69	229.84	0.579	37.9	20.0
S 150.0-6.3		6.30	27.36	34.85	1173.70	5.80	156.49	185.10	1921.60	238.80	0.573	36.5	18.8

# COLD FORMED SQUARE HOLLOW SECTIONS

MS EN 10219 / BS EN 10219 / MANUFACTURER'S STANDARD

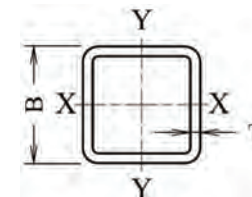

Tube Ref. No.(TRN)	Specified Dimension		Mass per unit length	Cross Sectional Area	Second Moment of Area	Radius of Gyration	Elastic Section Modulus	Plastic Section Modulus	Torsional Inertia Constant	Torsional Modulus Constant	Superficial area per meter length	Nominal length per tonne	Ratio for Local Buckling
	Size	Thickness											Flange
	B X B	T	M	A	I	i	$W_{el}$	$W_{pl}$	$L_t$	$C_t$	$A_s$		B/T
	mm	mm	Kg/m	cm <sup>2</sup>	cm <sup>4</sup>	cm	cm <sup>3</sup>	cm <sup>3</sup>	cm <sup>4</sup>	cm <sup>3</sup>	m <sup>2</sup> /m	m	
S 150.0-8.0	150 x 150	8.00	33.95	43.24	1411.80	5.71	188.24	226.00	2364.20	289.00	0.566	29.5	13.8
S 150.0-9.0		9.00	37.66	47.98	1537.40	5.66	204.99	248.20	2608.10	316.00	0.561	26.6	11.7
S 150.0-10.0		10.00	41.26	52.57	1650.00	5.61	220.00	269.00	2837.67	341.00	0.557	24.2	10.0
S 175.0-4.5	175 x 175	4.50	23.68	30.17	1448.83	6.93	165.58	191.75	2264.90	248.60	0.685	42.2	33.9
S 175.0-5.0		5.00	26.18	33.36	1590.86	6.91	181.81	211.24	2498.33	273.05	0.683	38.2	30.0
S 175.0-6.0		6.00	31.11	39.63	1864.03	6.86	213.03	249.15	2954.17	320.18	0.679	32.1	24.2
S 175.0-6.3		6.30	32.57	41.49	1943.18	6.84	222.08	260.25	3088.05	333.86	0.678	30.7	22.8
S 175.0-8.0		8.00	40.66	51.79	2367.89	6.76	270.62	320.75	3821.58	407.53	0.673	24.6	16.9
S 175.0-9.0		9.00	44.73	56.98	2599.21	6.75	297.05	354.47	4233.04	447.88	0.669	22.4	14.4
S 175.0-10.0		10.00	49.11	62.57	2817.20	6.71	321.97	386.83	4629.57	486.09	0.666	20.4	12.5
S 200.0-4.5	200 x 200	4.50	27.21	34.67	2191.54	7.95	219.15	252.86	3408.36	328.93	0.785	36.7	39.4
S 200.0-5.0		5.00	30.11	38.36	2410.09	7.93	241.01	278.87	3763.30	361.82	0.783	33.2	35.0
S 200.0-6.0		6.00	35.82	45.63	2832.75	7.88	283.28	329.67	4458.81	425.51	0.779	27.9	28.3
S 200.0-6.3		6.30	37.25	47.45	2921.50	7.85	292.15	341.20	4682.20	443.50	0.773	26.8	26.7
S 200.0-8.0		8.00	46.51	59.24	3566.30	7.76	356.63	420.90	5815.30	543.60	0.766	21.5	20.0
S 200.0-9.0		9.00	51.79	65.98	3918.50	7.71	391.85	465.30	6454.10	598.90	0.761	19.3	17.2
S 200.0-10.0		10.00	56.96	72.57	4251.00	7.65	425.10	508.10	7071.90	651.50	0.757	17.6	15.0
S 250.0-5.0	250 x 250	5.00	37.96	48.36	4805.00	9.97	384.40	442.30	7443.00	576.80	0.983	26.3	45.0
S 250.0-6.0		6.00	45.24	57.63	5672.00	9.92	453.76	524.40	8842.50	681.20	0.979	22.1	36.7
S 250.0-6.3		6.30	47.41	60.39	5872.60	9.86	469.81	544.40	9290.40	711.20	0.978	21.1	34.7
S 250.0-8.0		8.00	59.07	75.79	7229.20	9.77	578.34	675.80	11597.90	878.20	0.973	16.9	26.3
S 250.0-9.0		9.00	65.92	84.67	7983.80	9.71	638.70	750.00	12913.50	971.70	0.969	15.0	22.8
S 250.0-10.0		10.00	72.66	92.57	8706.70	9.70	696.54	822.00	14197.50	1061.80	0.957	13.8	20.0

# COLD FORMED RECTANGULAR HOLLOW SECTIONS

MS EN 10219 / BS EN 10219 / MANUFACTURER'S STANDARD

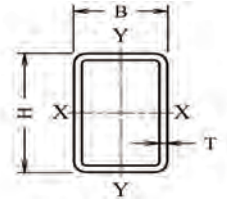

Tube Ref. No.(TRN)	Specified Dimension		Mass per unit length	Cross Sectional Area	Second Moment of Area		Radius of Gyration		Elastic Section Modulus		Plastic Section Modulus		Torsional Inertia Constant	Torsional Modulus Constant	Superficial area per meter length	Nominal length per tonne	Ratio for Local Buckling	
	Size	Thickness			I <sub>xx</sub>	I <sub>yy</sub>	i <sub>xx</sub>	i <sub>yy</sub>	W <sub>elxx</sub>	W <sub>elyy</sub>	W <sub>plx</sub>	W <sub>ply</sub>					L <sub>t</sub>	C <sub>t</sub>
	H X B	T	M	A									cm <sup>4</sup>	cm <sup>4</sup>	cm	cm		
	mm	mm	Kg/m	cm <sup>2</sup>	cm <sup>4</sup>	cm <sup>4</sup>	cm	cm	cm <sup>3</sup>	cm <sup>3</sup>	cm <sup>3</sup>	cm <sup>3</sup>	cm <sup>4</sup>	cm <sup>3</sup>	m <sup>2</sup> /m	m	B/T	H/T
R38.0x19.0-1.0	38x19	1.00	0.84	1.07	1.99	0.68	1.36	0.79	1.05	0.71	1.30	0.80	1.65	1.23	0.111	1185.8	14.0	33.0
R38.0x19.0-1.2		1.20	1.00	1.27	2.32	0.78	1.35	0.78	1.22	0.82	1.53	0.94	1.93	1.43	0.110	1000.4	10.8	26.7
R38.0x19.0-1.5		1.50	1.23	1.56	2.77	0.93	1.33	0.77	1.46	0.98	1.85	1.14	2.33	1.70	0.109	815.5	7.7	20.3
R38.0x25.0-1.0	38x25	1.00	0.94	1.19	2.40	1.26	1.42	1.03	1.26	1.01	1.52	1.14	2.63	1.66	0.123	1066.7	20.0	33.0
R38.0x25.0-1.2		1.20	1.11	1.42	2.80	1.47	1.41	1.02	1.48	1.17	1.79	1.35	3.10	1.94	0.122	898.8	15.8	26.7
R38.0x25.0-1.5		1.50	1.37	1.74	3.37	1.76	1.39	1.00	1.77	1.40	2.18	1.63	3.78	2.33	0.121	731.3	11.7	20.3
R40.0x20.0-1.0	40x20	1.00	0.89	1.13	2.33	0.80	1.43	0.84	1.17	0.80	1.45	0.90	1.93	1.38	0.117	1123.1	15.0	35.0
R40.0x20.0-1.2		1.20	1.06	1.35	2.73	0.92	1.42	0.83	1.36	0.92	1.71	1.05	2.27	1.60	0.116	946.9	11.7	28.3
R40.0x20.0-1.5		1.50	1.30	1.65	3.27	1.10	1.41	0.81	1.63	1.10	2.07	1.27	2.74	1.91	0.115	771.1	8.3	21.7
R40.0x20.0-2.0		2.00	1.68	2.14	4.05	1.34	1.38	0.79	2.02	1.34	2.61	1.60	3.45	2.36	0.113	596.1	5.0	15.0
R40.0x20.0-2.3		2.30	1.89	2.41	4.45	1.47	1.36	0.78	2.23	1.47	2.91	1.77	3.83	2.58	0.112	528.1	3.7	12.4
R40.0x20.0-2.5		2.50	2.03	2.59	4.69	1.54	1.35	0.77	2.35	1.54	3.09	1.88	4.06	2.72	0.111	492.0	3.0	11.0
R40.0x20.0-3.0		3.00	2.36	3.01	5.21	1.68	1.32	0.75	2.60	1.68	3.50	2.12	4.57	3.00	0.110	423.5	1.7	8.3
R50.0x25.0-1.0	50x25	1.00	1.13	1.43	4.69	1.60	1.81	1.06	1.87	1.28	2.31	1.43	3.85	2.22	0.147	888.2	20.0	45.0
R50.0x25.0-1.2		1.20	1.34	1.71	5.50	1.88	1.80	1.05	2.20	1.50	2.73	1.69	4.54	2.59	0.146	747.0	15.8	36.7
R50.0x25.0-1.5		1.50	1.65	2.10	6.65	2.25	1.77	1.03	2.81	1.90	3.33	2.05	5.54	3.13	0.145	606.0	11.7	28.3
R50.0x25.0-2.0		2.00	2.15	2.74	8.38	2.81	1.75	1.01	3.35	2.25	4.26	2.62	7.06	3.92	0.143	465.4	7.5	20.0
R50.0x25.0-2.3		2.30	2.44	3.10	9.31	3.10	1.73	1.00	3.72	2.48	4.78	2.92	7.90	4.34	0.142	410.6	5.9	16.7
R50.0x25.0-2.5		2.50	2.62	3.34	9.89	3.28	1.72	0.99	3.95	2.62	5.11	3.12	8.43	4.60	0.141	381.5	5.0	15.0
R50.0x25.0-3.0		3.00	3.07	3.91	11.2	3.67	1.69	0.97	4.47	2.93	5.86	3.56	9.64	5.18	0.140	325.9	3.3	11.7
R50.0x30.0-1.0	50x30	1.00	1.20	1.53	5.29	2.41	1.86	1.25	2.11	1.61	2.56	1.80	5.26	2.70	0.157	830.3	25.0	45.0
R50.0x30.0-1.2		1.20	1.43	1.83	6.22	2.83	1.85	1.25	2.49	1.89	3.02	2.13	6.22	3.17	0.156	697.9	20.0	36.7
R50.0x30.0-2.0		2.00	2.31	2.94	9.54	4.29	1.80	1.21	3.81	2.86	4.74	3.33	9.77	4.84	0.153	433.7	10.0	20.0

NOTE: Sizes with shaded are uncommon size

# COLD FORMED RECTANGULAR HOLLOW SECTIONS

MS EN 10219 / BS EN 10219 / MANUFACTURER'S STANDARD

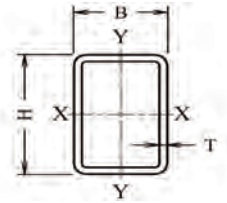

Tube Ref. No.(TRN)	Specified Dimension		Mass per unit length	Cross Sectional Area	Second Moment of Area		Radius of Gyration		Elastic Section Modulus		Plastic Section Modulus		Torsional Inertia Constant	Torsional Modulus Constant	Superficial area per meter length	Nominal length per tonne	Ratio for Local Buckling	
	Size	Thickness			$I_{xx}$	$I_{yy}$	$i_{xx}$	$i_{yy}$	$W_{elxx}$	$W_{elyy}$	$W_{plx}$	$W_{ply}$					$L_t$	$C_t$
	H X B	T	M	A									$cm^4$	$cm^4$	cm	cm		
	mm	mm	Kg/m	$cm^2$	$cm^4$	$cm^4$	cm	cm	$cm^3$	$cm^3$	$cm^3$	$cm^3$	$cm^4$	$cm^3$	$m^2/m$	m	B/T	H/T
R50.0x30.0-2.5	50x30	2.50	2.82	3.59	11.3	5.05	1.77	1.19	4.52	3.37	5.70	3.98	11.74	5.72	0.151	354.9	7.0	15.0
R50.0x30.0-3.0		3.00	3.30	4.21	12.8	5.70	1.75	1.16	5.13	3.80	6.57	4.58	13.53	6.49	0.150	302.7	5.0	11.7
R50.0x30.0-4.0		4.00	4.20	5.35	15.3	6.69	1.69	1.12	6.10	4.46	8.05	5.58	16.53	7.71	0.146	238.2	2.5	7.5
R60.0x40.0-2.0	60x40	2.00	2.93	3.74	18.4	9.83	2.22	1.62	6.14	4.92	7.47	5.65	20.70	8.12	0.193	340.9	15.0	25.0
R60.0x40.0-2.5		2.50	3.60	4.59	22.1	11.7	2.19	1.60	7.36	5.87	9.06	6.84	25.14	9.72	0.191	277.6	11.0	19.0
R60.0x40.0-3.0		3.00	4.25	5.41	25.4	13.4	2.17	1.58	8.46	6.72	10.5	7.94	29.28	11.17	0.190	235.5	8.3	15.0
R60.0x40.0-4.0		4.00	5.45	6.95	31.0	16.3	2.11	1.53	10.3	8.14	13.2	9.89	36.67	13.65	0.186	183.3	5.0	10.0
R60.0x40.0-5.0		5.00	6.56	8.36	35.3	18.4	2.06	1.48	11.8	9.21	15.4	11.52	42.85	15.60	0.183	152.4	3.0	7.0
R65.0x38.0-1.5	65x38	1.50	2.31	2.94	16.9	7.37	2.39	1.58	5.18	3.88	6.32	4.37	16.39	6.53	0.201	433.0	20.3	38.3
R65.0x38.0-1.9		1.90	2.89	3.68	20.7	9.00	2.37	1.56	6.36	4.74	7.82	5.40	20.30	8.00	0.199	346.5	15.0	29.2
R65.0x38.0-2.0		2.00	3.03	3.86	21.6	9.39	2.37	1.56	6.64	4.94	8.18	5.64	21.24	8.35	0.199	330.3	14.0	27.5
R65.0x38.0-2.3		2.30	3.45	4.39	24.2	10.5	2.35	1.55	7.46	5.53	9.24	6.37	24.01	9.36	0.198	290.2	11.5	23.3
R65.0x38.0-2.5		2.50	3.72	4.74	25.9	11.2	2.34	1.54	7.97	5.90	9.92	6.83	25.79	10.00	0.197	268.8	10.2	21.0
R65.0x38.0-3.0		3.00	4.39	5.59	29.8	12.8	2.31	1.51	9.18	6.75	11.5	7.93	30.02	11.50	0.196	228.0	7.7	16.7
R65.0x38.0-4.0		4.00	5.64	7.19	36.5	15.5	2.25	1.47	11.2	8.17	14.5	9.89	37.55	14.04	0.192	177.2	4.5	11.3
R75.0x25.0-1.5		75x25	1.50	2.24	2.85	18.7	3.29	2.56	1.07	4.98	2.63	6.43	2.94	9.39	4.78	0.195	446.7	11.7
R75.0x25.0-1.9	1.90		2.80	3.56	22.8	3.98	2.53	1.06	6.09	3.18	7.94	3.61	11.50	5.80	0.193	357.6	8.2	34.5
R75.0x25.0-2.0	2.00		2.93	3.74	23.8	4.14	2.53	1.05	6.36	3.31	8.31	3.77	12.01	6.04	0.193	340.9	7.5	32.5
R75.0x25.0-2.3	2.30		3.34	4.25	26.7	4.59	2.51	1.04	7.12	3.67	9.37	4.23	13.46	6.72	0.192	299.6	5.9	27.6
R75.0x25.0-2.5	2.50		3.60	4.59	28.5	4.87	2.49	1.03	7.60	3.89	10.1	4.53	14.38	7.14	0.191	277.6	5.0	25.0
R75.0x25.0-3.0	3.00		4.25	5.41	32.7	5.49	2.46	1.01	8.72	4.39	11.7	5.21	16.50	8.10	0.190	235.5	3.3	20.0
R75.0x25.0-4.0	4.00		5.45	6.95	39.7	6.46	2.39	0.96	10.6	5.17	14.6	6.39	20.01	9.61	0.186	183.3	1.3	13.8
R75.0x25.0-4.5	4.50		6.02	7.67	42.6	6.81	2.36	0.94	11.3	5.45	15.8	6.89	21.40	10.19	0.185	166.1	0.6	11.7

NOTE: Sizes with shaded are uncommon size



# COLD FORMED RECTANGULAR HOLLOW SECTIONS

MS EN 10219 / BS EN 10219 / MANUFACTURER'S STANDARD

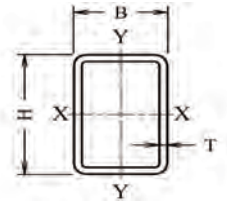

Tube Ref. No.(TRN)	Specified Dimension		Mass per unit length	Cross Sectional Area	Second Moment of Area		Radius of Gyration		Elastic Section Modulus		Plastic Section Modulus		Torsional Inertia Constant	Torsional Modulus Constant	Superficial area per meter length	Nominal length per tonne	Ratio for Local Buckling	
	Size	Thickness			$I_{xx}$	$I_{yy}$	$i_{xx}$	$i_{yy}$	$W_{elxx}$	$W_{elyy}$	$W_{plx}$	$W_{ply}$					$L_t$	$C_t$
	H X B	T	M	A									cm	cm	cm <sup>3</sup>	cm <sup>3</sup>		
	mm	mm	Kg/m	cm <sup>2</sup>	cm <sup>4</sup>	cm <sup>4</sup>	cm	cm	cm <sup>3</sup>	cm <sup>3</sup>	cm <sup>3</sup>	cm <sup>3</sup>	cm <sup>4</sup>	cm <sup>3</sup>	m <sup>2</sup> /m	m	B/T	H/T
R75.0x38.0-1.5	75x38	1.50	2.55	3.24	23.9	8.37	2.72	1.61	6.38	4.40	7.86	4.92	19.94	7.59	0.221	392.9	20.3	45.0
R75.0x38.0-1.9		1.90	3.18	4.06	29.4	10.2	2.69	1.59	7.85	5.39	9.75	6.08	24.71	9.30	0.219	314.0	15.0	34.5
R75.0x38.0-2.0		2.00	3.34	4.26	30.8	10.7	2.69	1.58	8.20	5.62	10.2	6.36	25.86	9.71	0.219	299.2	14.0	32.5
R75.0x38.0-2.3		2.30	3.81	4.85	34.6	12.0	2.67	1.57	9.23	6.30	11.5	7.19	29.24	10.90	0.218	262.6	11.5	27.6
R75.0x38.0-2.5		2.50	4.11	5.24	37.1	12.8	2.66	1.56	9.88	6.73	12.4	7.72	31.42	11.66	0.217	243.2	10.2	25.0
R75.0x38.0-3.0		3.00	4.86	6.19	42.8	14.7	2.63	1.54	11.4	7.72	14.5	8.98	36.62	13.43	0.216	205.9	7.7	20.0
R75.0x38.0-4.0		4.00	6.27	7.99	52.8	17.9	2.57	1.50	14.1	9.40	18.3	11.2	45.93	16.48	0.212	159.5	4.5	13.8
R75.0x38.0-4.5		4.50	6.94	8.84	57.1	19.2	2.54	1.47	15.2	10.1	19.9	12.3	50.04	17.77	0.211	144.1	3.4	11.7
R75.0x50.0-1.5	75x50	1.50	2.83	3.60	28.8	15.5	2.83	2.07	7.68	6.19	9.18	6.97	31.70	10.18	0.245	353.7	28.3	45.0
R75.0x50.0-1.9		1.90	3.54	4.51	36.8	19.6	2.86	2.08	9.82	7.85	11.8	8.88	39.5	12.5	0.243	282.3	21.3	34.5
R75.0x50.0-2.0		2.00	3.72	4.74	37.2	19.9	2.80	2.05	9.91	7.96	12.0	9.06	41.35	13.12	0.243	268.9	20.0	32.5
R75.0x50.0-2.3		2.30	4.24	5.40	41.9	22.4	2.79	2.04	11.2	8.96	13.6	10.3	46.92	14.78	0.242	235.8	16.7	27.6
R75.0x50.0-2.5		2.50	4.58	5.84	45.0	24.0	2.77	2.03	12.0	9.60	14.6	11.0	50.54	15.85	0.241	218.2	15.0	25.0
R75.0x50.0-3.0		3.00	5.42	6.91	52.2	27.8	2.75	2.00	13.9	11.1	17.1	12.9	59.27	18.38	0.240	184.4	11.7	20.0
R75.0x50.0-4.0		4.00	7.02	8.95	65.0	34.3	2.69	1.96	17.3	13.7	21.7	16.3	75.33	22.88	0.236	142.4	7.5	13.8
R75.0x50.0-4.5		4.50	7.79	9.92	70.6	37.2	2.67	1.94	18.8	14.9	23.8	17.9	82.66	24.86	0.235	128.4	6.1	11.7
R75.0x50.0-5.0		5.00	8.52	10.86	75.6	39.7	2.64	1.91	20.2	15.9	25.7	19.3	89.52	26.67	0.233	117.3	5.0	10.0
R75.0x50.0-6.0		6.00	9.92	12.63	84.4	44.1	2.58	1.87	22.5	17.6	29.2	21.9	101.82	29.79	0.229	100.8	3.3	7.5
R100.0x50.0-1.9	100x50	1.90	4.29	5.46	71.6	24.5	3.62	2.12	14.3	9.8	17.6	10.9	58.70	16.90	0.293	233.2	21.3	47.6
R100.0x50.0-2.0		2.00	4.50	5.74	75.0	25.7	3.62	2.12	15.0	10.3	18.5	11.5	61.60	17.70	0.293	222.0	20.0	45.0
R100.0x50.0-2.3		2.30	5.14	6.55	84.8	29.0	3.60	2.10	17.0	11.6	21.0	13.0	69.90	20.00	0.292	194.4	16.7	38.5
R100.0x50.0-2.5		2.50	5.56	7.09	91.2	31.1	3.59	2.09	18.2	12.4	22.7	14.0	75.40	21.50	0.291	179.7	15.0	35.0
R100.0x50.0-3.0		3.00	6.60	8.41	106.5	36.1	3.56	2.07	21.3	14.4	26.7	16.4	88.60	25.00	0.290	151.5	11.7	28.3

# COLD FORMED RECTANGULAR HOLLOW SECTIONS

MS EN 10219 / BS EN 10219 / MANUFACTURER'S STANDARD

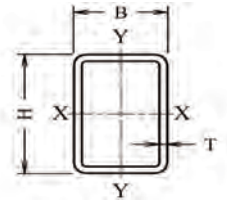

Tube Ref. No.(TRN)	Specified Dimension		Mass per unit length	Cross Sectional Area	Second Moment of Area		Radius of Gyration		Elastic Section Modulus		Plastic Section Modulus		Torsional Inertia Constant	Torsional Modulus Constant	Superficial area per meter length	Nominal length per tonne	Ratio for Local Buckling	
	Size	Thickness			I <sub>xx</sub>	I <sub>yy</sub>	i <sub>xx</sub>	i <sub>yy</sub>	W <sub>elxx</sub>	W <sub>elyy</sub>	W <sub>plx</sub>	W <sub>ply</sub>					L <sub>t</sub>	C <sub>t</sub>
	H X B	T	M	A									cm <sup>4</sup>	cm <sup>4</sup>	cm	cm		
	mm	mm	Kg/m	cm <sup>2</sup>	cm <sup>4</sup>	cm <sup>4</sup>	cm	cm	cm <sup>3</sup>	cm <sup>3</sup>	cm <sup>3</sup>	cm <sup>3</sup>	cm <sup>4</sup>	cm <sup>3</sup>	m <sup>2</sup> /m	m	B/T	H/T
R100.0x50.0-4.0	100x50	4.00	8.59	10.95	134.1	44.9	3.50	2.03	26.8	18.0	34.1	20.9	113.00	31.30	0.286	116.4	7.5	20.0
R100.0x50.0-4.5		4.50	9.55	12.17	146.6	48.9	3.47	2.00	29.3	19.5	37.6	23.0	124.30	34.20	0.285	104.7	6.1	17.2
R100.0x50.0-5.0		5.00	10.48	13.36	158.2	52.5	3.44	1.98	31.6	21.0	40.8	25.0	134.90	36.80	0.283	95.4	5.0	15.0
R100.0x50.0-6.0		6.00	12.27	15.63	178.8	58.7	3.38	1.94	35.8	23.5	46.9	28.5	154.20	41.40	0.279	81.5	3.3	11.7
R100.0x50.0-6.3		6.30	12.52	15.95	175.7	58.2	3.32	1.91	35.1	23.3	46.9	28.6	158.10	42.10	0.273	79.9	2.9	10.9
R100.0x75.0-2.3	100x75	2.30	6.05	7.70	112.28	72.30	3.82	3.06	22.5	19.3	26.6	21.9	138.34	30.98	0.342	165.4	27.6	38.5
R100.0x75.0-3.0		3.00	7.78	9.91	141.8	91.1	3.78	3.03	28.4	24.3	33.9	27.9	176.60	39.10	0.340	128.6	20.0	28.3
R100.0x75.0-3.2		3.20	8.26	10.53	149.8	96.2	3.77	3.02	30.0	25.6	35.9	29.5	187.30	41.30	0.339	121.0	18.4	26.3
R100.0x75.0-4.0		4.00	10.16	12.95	180.2	115.4	3.73	2.99	36.0	30.8	43.7	35.9	228.20	49.70	0.336	98.4	13.8	20.0
R100.0x75.0-4.5		4.50	11.32	14.42	197.9	126.5	3.71	2.96	39.6	33.7	48.3	39.6	252.70	54.60	0.335	88.4	11.7	17.2
R100.0x75.0-5.0		5.00	12.45	15.86	214.6	137.0	3.68	2.94	42.9	36.5	52.7	43.2	276.20	59.20	0.333	80.3	10.0	15.0
R100.0x75.0-6.0		6.00	14.63	18.63	245.1	156.0	3.63	2.89	49.0	41.6	61.0	49.9	320.40	67.70	0.329	68.4	7.5	11.7
R100.0x75.0-6.3		6.30	14.99	19.10	244.9	156.3	3.58	2.86	49.0	41.7	61.6	50.5	332.50	69.50	0.323	66.7	6.9	10.9
R125.0x50.0-2.3	125x50	2.30	6.05	7.70	148.24	35.50	4.39	2.15	23.7	14.2	29.9	15.7	93.92	25.25	0.342	165.4	16.7	49.3
R125.0x50.0-2.5		2.50	6.55	8.34	159.6	38.1	4.37	2.14	25.5	15.2	32.3	17.0	101.30	27.10	0.341	152.8	15.0	45.0
R125.0x50.0-3.0		3.00	7.78	9.91	187.0	44.4	4.34	2.12	29.9	17.7	38.1	20.0	119.00	31.60	0.340	128.6	11.7	36.7
R125.0x50.0-4.0		4.00	10.16	12.95	237.5	55.6	4.28	2.07	38.0	22.2	49.0	25.5	152.10	39.80	0.336	98.4	7.5	26.3
R125.0x50.0-4.5		4.50	11.32	14.42	260.7	60.6	4.25	2.05	41.7	24.2	54.2	28.1	167.40	43.50	0.335	88.4	6.1	22.8
R125.0x50.0-5.0		5.00	12.45	15.86	282.5	65.2	4.22	2.03	45.2	26.1	59.1	30.6	182.00	47.00	0.333	80.3	5.0	20.0
R125.0x50.0-6.0		6.00	14.63	18.63	322.0	73.3	4.16	1.98	51.5	29.3	68.3	35.1	208.50	53.10	0.329	68.4	3.3	15.8
R125.0x50.0-6.3		6.30	14.99	19.10	319.4	73.3	4.09	1.96	51.1	29.3	68.8	35.5	214.60	54.20	0.323	66.7	2.9	14.8
R125.0x75.0-3.0	125x75	3.00	8.96	11.41	242.8	110.5	4.61	3.11	38.9	29.5	47.3	33.3	242.90	49.50	0.390	111.7	20.0	36.7
R125.0x75.0-4.0		4.00	11.73	14.95	310.8	140.7	4.56	3.07	49.7	37.5	61.1	43.0	314.50	63.10	0.386	85.2	13.8	26.3
R125.0x75.0-4.5		4.50	13.08	16.67	342.4	154.5	4.53	3.04	54.8	41.2	67.7	47.5	348.60	69.50	0.385	76.4	11.7	22.8
R125.0x75.0-5.0		5.00	14.41	18.36	372.5	167.7	4.50	3.02	59.6	44.7	74.1	52.0	381.50	75.60	0.383	69.4	10.0	20.0
R125.0x75.0-6.0		6.00	16.98	21.63	428.3	191.8	4.45	2.98	68.5	51.1	86.2	60.3	443.80	86.70	0.379	58.9	7.5	15.8

# COLD FORMED RECTANGULAR HOLLOW SECTIONS

MS EN 10219 / BS EN 10219 / MANUFACTURER'S STANDARD

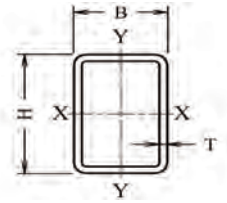

Tube Ref. No.(TRN)	Specified Dimension		Mass per unit length	Cross Sectional Area	Second Moment of Area		Radius of Gyration		Elastic Section Modulus		Plastic Section Modulus		Torsional Inertia Constant	Torsional Modulus Constant	Superficial area per meter length	Nominal length per tonne	Ratio for Local Buckling	
	Size	Thickness			$I_{xx}$	$I_{yy}$	$i_{xx}$	$i_{yy}$	$W_{elxx}$	$W_{elyy}$	$W_{plx}$	$W_{ply}$					$L_t$	$C_t$
	H X B	T	M	A									cm <sup>4</sup>	cm <sup>4</sup>	cm	cm		
	mm	mm	Kg/m	cm <sup>2</sup>	cm <sup>4</sup>	cm <sup>4</sup>	cm	cm	cm <sup>3</sup>	cm <sup>3</sup>	cm <sup>3</sup>	cm <sup>3</sup>	cm <sup>4</sup>	cm <sup>3</sup>	m <sup>2</sup> /m	m	B/T	H/T
R150.0x50.0-3.0	150x50	3.00	8.96	11.41	298.5	52.6	5.12	2.15	39.8	21.1	51.4	23.5	150.20	38.30	0.390	111.7	11.7	45.0
R150.0x50.0-4.0		4.00	11.73	14.95	381.4	66.2	5.05	2.10	50.9	26.5	66.5	30.1	192.10	48.30	0.386	85.2	7.5	32.5
R150.0x50.0-4.5		4.50	13.08	16.67	419.8	72.2	5.02	2.08	56.0	28.9	73.6	33.2	211.60	52.90	0.385	76.4	6.1	28.3
R150.0x50.0-5.0		5.00	14.41	18.36	456.3	77.9	4.99	2.06	60.8	31.1	80.5	36.2	230.10	57.10	0.383	69.4	5.0	25.0
R150.0x50.0-6.0		6.00	16.98	21.63	523.5	87.9	4.92	2.02	69.8	35.2	93.5	41.4	264.00	64.80	0.379	58.9	3.3	20.0
R150.0x50.0-6.3		6.30	17.47	22.25	522.8	88.5	4.85	1.99	69.7	35.4	94.6	42.4	272.20	66.30	0.373	57.3	2.9	18.8
R150.0x75.0-3.0	150x75	3.00	10.13	12.91	379.6	130.0	5.42	3.17	50.6	34.7	62.5	38.7	311.80	59.80	0.440	98.7	20.0	45.0
R150.0x75.0-4.0		4.00	13.30	16.95	488.0	165.9	5.37	3.13	65.1	44.2	81.1	50.1	404.30	76.60	0.436	75.2	13.8	32.5
R150.0x75.0-4.5		4.50	14.85	18.92	538.9	182.5	5.34	3.11	71.9	48.7	90.0	55.5	448.40	84.40	0.435	67.3	11.7	28.3
R150.0x75.0-5.0		5.00	16.37	20.86	587.7	198.4	5.31	3.08	78.4	52.9	98.6	60.7	491.00	91.90	0.433	61.1	10.0	25.0
R150.0x75.0-6.0		6.00	19.34	24.63	679.1	227.6	5.25	3.04	90.5	60.7	115.1	70.6	572.00	105.80	0.429	51.7	7.5	20.0
R150.0x75.0-6.3		6.30	19.94	25.40	685.6	230.9	5.20	3.01	91.4	61.6	117.2	72.2	595.80	109.10	0.423	50.2	6.9	18.8
R150.0x75.0-8.0		8.00	24.53	31.24	806.3	269.0	5.08	2.93	107.5	71.7	140.8	86.3	714.50	128.50	0.416	40.8	4.4	13.8
R150.0x75.0-9.0		9.00	27.07	34.48	865.5	287.3	5.01	2.89	115.4	76.6	153.0	93.6	775.20	138.10	0.411	36.9	3.3	11.7
R150.0x100.0-4.0	150x100	4.00	14.87	18.95	594.6	318.6	5.60	4.10	79.3	63.7	95.7	72.5	661.60	104.90	0.486	67.2	20.0	32.5
R150.0x100.0-4.5		4.50	16.62	21.17	658.1	352.0	5.58	4.08	87.7	70.4	106.3	80.5	736.10	116.10	0.485	60.2	17.2	28.3
R150.0x100.0-5.0		5.00	18.33	23.36	719.2	384.0	5.55	4.05	95.9	76.8	116.7	88.3	808.70	126.80	0.483	54.5	15.0	25.0
R150.0x100.0-6.0		6.00	21.69	27.63	834.7	444.2	5.50	4.01	111.3	88.8	136.7	103.3	948.30	147.10	0.479	46.1	11.7	20.0
R150.0x100.0-6.3		6.30	22.41	28.55	848.3	452.7	5.45	3.98	113.1	90.5	139.9	105.9	991.60	152.30	0.473	44.6	10.9	18.8
R150.0x100.0-8.0		8.00	27.67	35.24	1008.1	535.7	5.35	3.90	134.4	107.1	169.2	127.9	1205.90	181.80	0.466	36.1	7.5	13.8
R150.0x100.0-9.0		9.00	30.60	38.98	1089.5	577.5	5.29	3.85	145.3	115.5	184.8	139.5	1320.30	197.10	0.461	32.7	6.1	11.7

# COLD FORMED RECTANGULAR HOLLOW SECTIONS

MS EN 10219 / BS EN 10219 / MANUFACTURER'S STANDARD

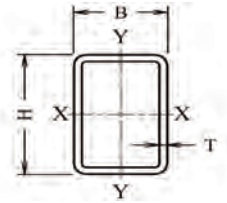

Tube Ref. No.(TRN)	Specified Dimension		Mass per unit length	Cross Sectional Area	Second Moment of Area		Radius of Gyration		Elastic Section Modulus		Plastic Section Modulus		Torsional Inertia Constant	Torsional Modulus Constant	Superficial area per meter length	Nominal length per tonne	Ratio for Local Buckling	
	Size	Thickness			$I_{xx}$	$I_{yy}$	$i_{xx}$	$i_{yy}$	$W_{elxx}$	$W_{elyy}$	$W_{plx}$	$W_{ply}$					$L_t$	$C_t$
	H X B	T	M	A									$cm^4$	$cm^4$	cm	cm		
	mm	mm	Kg/m	$cm^2$	$cm^4$	$cm^4$	cm	cm	$cm^3$	$cm^3$	$cm^3$	$cm^3$	$cm^4$	$cm^3$	$m^2/m$	m	B/T	H/T
R200.0x100.0-4.0	200x100	4.00	18.01	22.95	1199.7	410.8	7.23	4.23	120.0	82.2	148.0	91.7	985.40	141.80	0.586	55.5	20.0	45.0
R200.0x100.0-4.5		4.50	20.15	25.67	1331.4	454.6	7.20	4.21	133.1	90.9	164.9	102.0	1097.10	157.10	0.585	49.6	17.2	39.4
R200.0x100.0-5.0		5.00	22.26	28.36	1456.3	496.9	7.17	4.19	145.9	99.4	181.4	112.1	1206.30	171.90	0.583	44.9	15.0	35.0
R200.0x100.0-6.0		6.00	26.40	33.63	1703.3	576.9	7.12	4.14	170.3	115.4	213.3	131.5	1417.00	200.10	0.579	37.9	11.7	28.3
R200.0x100.0-6.3		6.30	27.36	34.85	1739.2	591.1	7.06	4.12	173.9	118.2	219.1	135.4	1482.80	207.60	0.573	36.6	10.9	26.7
R200.0x100.0-8.0		8.00	33.95	43.24	2090.8	705.4	6.95	4.04	209.1	141.1	267.3	164.7	1810.70	249.60	0.566	29.5	7.5	20.0
R200.0x100.0-9.0		9.00	37.66	47.98	2275.6	764.4	6.89	3.99	227.6	152.9	293.4	180.5	1988.30	271.80	0.561	26.6	6.1	17.2
R200.0x100.0-10.0		10.00	41.26	52.57	2444.4	817.7	6.82	3.94	244.4	163.5	318.1	195.2	2154.10	292.10	0.557	24.2	5.0	15.0
R200.0x150.0-4.0	200x150	4.00	21.15	26.95	1583.9	1021.0	7.67	6.16	158.4	136.1	187.2	154.1	1942.00	218.50	0.686	47.3	32.5	45.0
R200.0x150.0-4.5		4.50	23.68	30.17	1761.5	1134.5	7.64	6.13	176.1	151.3	208.9	171.8	2168.50	243.00	0.685	42.2	28.3	39.4
R200.0x150.0-5.0		5.00	26.18	33.36	1934.7	1245.0	7.62	6.11	193.5	166.0	230.1	189.2	2391.40	266.80	0.683	38.2	25.0	35.0
R200.0x150.0-6.0		6.00	31.11	39.63	2268.0	1457.1	7.56	6.06	226.8	194.3	271.5	223.1	2826.20	312.70	0.679	32.1	20.0	28.3
R200.0x150.0-6.3		6.30	32.30	41.15	2330.4	1499.2	7.53	6.04	233.0	199.9	280.1	230.4	2965.40	325.50	0.673	31.0	18.8	26.7
R200.0x150.0-8.0		8.00	40.23	51.24	2828.5	1815.5	7.43	5.95	282.9	242.4	344.1	282.8	3664.90	396.40	0.666	24.9	13.8	20.0
R200.0x150.0-9.0		9.00	44.73	56.98	3097.0	1985.3	7.37	5.90	309.7	264.7	379.4	311.7	4054.80	435.10	0.661	22.4	11.7	17.2
R200.0x150.0-10.0		10.00	49.11	62.57	3347.7	2143.4	7.31	5.85	334.8	285.8	413.1	339.2	4428.40	471.40	0.657	20.4	10.0	15.0
R225.0x75.0-4.5	225x75	4.50	20.15	25.67	1511.4	266.5	7.67	3.22	134.3	71.1	173.6	79.3	760.47	129.18	0.585	49.6	11.7	45.0
R225.0x75.0-5.0		5.00	22.26	28.36	1655.7	290.4	7.64	3.20	147.2	77.4	190.9	87.0	833.49	140.94	0.583	44.9	10.0	40.0
R225.0x75.0-6.0		6.00	26.40	33.63	1930.8	334.9	7.58	3.16	171.6	89.3	224.3	101.7	972.71	163.02	0.579	37.9	7.5	32.5
R225.0x75.0-6.3		6.30	27.62	35.19	2009.8	347.5	7.56	3.14	178.6	92.7	234.1	105.9	1012.72	169.29	0.578	36.2	6.9	30.7
R225.0x75.0-8.0		8.00	34.38	43.79	2427.6	412.1	7.45	3.07	215.8	109.9	286.6	128.6	1224.13	201.77	0.573	29.1	4.4	23.1
R225.0x75.0-9.0		9.00	38.21	48.67	2650.0	445.0	7.38	3.02	235.6	118.7	315.5	140.8	1336.44	218.58	0.569	26.2	3.3	20.0
R225.0x75.0-10.0		10.00	41.94	53.42	2855.6	474.4	7.31	2.98	253.8	126.5	342.9	152.2	1439.92	233.78	0.566	23.8	2.5	17.5

NOTE: Sizes with shaded are uncommon size



# COLD FORMED RECTANGULAR HOLLOW SECTIONS

MS EN 10219 / BS EN 10219 / MANUFACTURER'S STANDARD

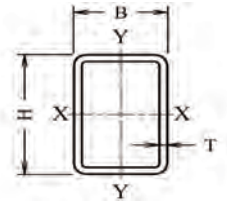

Tube Ref. No.(TRN)	Specified Dimension		Mass per unit length	Cross Sectional Area	Second Moment of Area		Radius of Gyration		Elastic Section Modulus		Plastic Section Modulus		Torsional Inertia Constant	Torsional Modulus Constant	Superficial area per meter length	Nominal length per tonne	Ratio for Local Buckling	
	Size	Thickness			$I_{xx}$	$I_{yy}$	$i_{xx}$	$i_{yy}$	$W_{elxx}$	$W_{elyy}$	$W_{plx}$	$W_{ply}$					$L_t$	$C_t$
	H X B	T	M	A									$cm^4$	$cm^4$	cm	cm		
	mm	mm	Kg/m	$cm^2$	$cm^4$	$cm^4$	cm	cm	$cm^3$	$cm^3$	$cm^3$	$cm^3$	$cm^4$	$cm^3$	$m^2/m$	m	B/T	H/T
R250.0x150.0-4.5	250x150	4.50	27.21	34.67	3003.8	1372.8	9.31	6.29	240.3	183.0	289.9	204.6	2976.90	306.50	0.785	36.7	28.3	50.6
R250.0x150.0-5.0		5.00	30.11	38.67	3304.2	1508.0	9.28	6.27	264.3	201.1	319.8	225.5	3284.50	336.90	0.783	33.2	25.0	45.0
R250.0x150.0-6.0		6.00	35.82	45.63	3885.6	1768.3	9.23	6.23	310.8	135.8	378.0	266.3	3885.80	395.60	0.779	27.9	20.0	36.7
R250.0x150.0-6.3		6.30	37.25	47.45	4001.4	1824.6	9.18	6.20	320.1	243.3	390.9	275.7	4077.70	412.20	0.773	26.8	18.8	34.7
R250.0x150.0-8.0		8.00	46.51	59.24	4885.8	2219.2	9.08	6.12	390.9	295.9	482.2	339.6	5050.40	504.00	0.766	21.5	13.8	26.3
R250.0x150.0-9.0		9.00	51.79	65.98	5368.9	2433.3	9.02	6.07	429.5	324.4	533.1	375.1	5595.80	554.30	0.761	19.3	11.7	22.8
R250.0x150.0-10.0		10.00	56.96	72.57	5825.0	2634.2	8.96	6.02	466.0	351.2	582.0	409.2	6120.70	602.10	0.757	17.6	10.0	20.0
R300.0x100.0-6.0	300x100	6.00	35.82	45.63	4776.8	842.4	10.23	4.30	318.5	168.5	411.4	187.9	2403.50	306.20	0.779	27.9	11.7	45.0
R300.0x100.0-6.3		6.30	37.25	47.45	4906.8	868.1	10.17	4.28	327.1	173.6	424.9	194.4	2515.20	318.30	0.773	26.8	10.9	42.6
R300.0x100.0-8.0		8.00	46.51	59.24	5977.9	1044.8	10.05	4.20	398.5	209.0	523.5	238.3	3080.30	385.20	0.766	21.5	7.5	32.5
R300.0x100.0-10.0		10.00	56.96	72.57	7106.0	1224.4	9.90	4.11	473.7	244.9	630.9	285.2	3681.00	454.50	0.757	17.6	5.0	25.0
R300.0x200.0-5.0	300x200	5.00	37.96	48.36	6241.1	3360.9	11.36	8.34	416.1	336.1	495.7	376.4	6835.80	551.90	0.983	26.3	35.0	55.0
R300.0x200.0-6.0		6.00	45.24	57.63	7370.2	6962.2	11.31	8.29	491.3	396.2	587.8	446.1	8115.20	651.20	0.979	22.1	28.3	45.0
R300.0x200.0-6.3		6.30	47.14	60.05	7624.4	4103.8	11.27	8.27	508.3	410.4	609.9	463.2	8523.50	679.80	0.973	21.2	26.7	42.6
R300.0x200.0-8.0		8.00	59.07	75.24	9389.3	5041.7	11.17	8.19	626.0	504.2	757.1	674.5	10626.50	838.40	0.966	16.9	20.0	32.5
R300.0x200.0-9.0		9.00	65.92	83.98	10371.4	5561.3	11.11	8.14	691.4	556.1	840.2	637.2	11822.40	927.00	0.961	15.2	17.2	28.3
R300.0x200.0-10.0		10.00	72.66	92.57	11312.7	6057.7	11.05	8.09	754.2	605.8	920.9	698.1	12987.10	1012.20	0.957	13.8	15.0	25.0

NOTE: Sizes with shaded are uncommon size

# COLD FORMED CIRCULAR HOLLOW SECTIONS

MS EN 10219 / BS EN 10219 / MANUFACTURER'S STANDARD

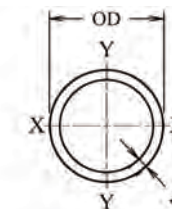

Tube Ref. No.(TRN)	Specified Dimension		Weight per unit length	Cross Sectional Area	Second Moment of Area	Radius of Gyration	Elastic Section Modulus	Plastic Section Modulus	Torsional Inertia Constant	Torsional Modulus Constant	Superficial area per meter length	Nominal length per tonne	Ratio for Local Buckling
	Outside Diameter	Thickness											D/T
	D	T	M	A	I	i	$W_{el}$	$W_{pl}$	$L_t$	$C_t$	$A_s$		
	mm	mm	kg/m	cm <sup>2</sup>	cm <sup>4</sup>	cm	cm <sup>3</sup>	cm <sup>3</sup>	cm <sup>4</sup>	cm <sup>3</sup>	m <sup>2</sup> /m	m	
C 21.3-2.0	21.3	2.0	0.95	1.21	0.571	0.686	0.54	0.75	1.14	1.07	0.0669	1050.5	10.65
C 21.3-2.5		2.5	1.16	1.48	0.664	0.671	0.62	0.89	1.33	1.25	0.0669	862.7	8.52
C 21.3-3.0		3.0	1.35	1.72	0.741	0.656	0.70	1.01	1.48	1.39	0.0669	738.6	7.10
C 26.9-2.0	26.9	2.0	1.23	1.56	1.22	0.883	0.91	1.24	2.44	1.81	0.0845	814.2	13.45
C 26.9-2.5		2.5	1.50	1.92	1.44	0.867	1.07	1.49	2.88	2.14	0.0845	664.7	10.76
C 26.9-3.0		3.0	1.77	2.25	1.63	0.852	1.21	1.72	3.27	2.43	0.0845	565.5	8.97
C 33.7-2.0	33.7	2.0	1.56	1.99	2.51	1.12	1.49	2.01	5.02	2.98	0.106	639.6	16.85
C 33.7-2.5		2.5	1.92	2.45	3.00	1.11	1.78	2.44	6.00	3.56	0.106	519.9	13.48
C 33.7-3.0		3.0	2.27	2.89	3.44	1.09	2.04	2.84	6.88	4.08	0.106	440.3	11.23
C 42.4-2.0	42.4	2.0	1.99	2.54	5.19	1.43	2.45	3.27	10.38	4.90	0.133	501.8	21.20
C 42.4-2.5		2.5	2.46	3.13	6.26	1.41	2.95	3.99	12.52	5.91	0.133	406.5	16.96
C 42.4-3.0		3.0	2.91	3.71	7.25	1.40	3.42	4.67	14.49	6.84	0.133	343.1	14.13
C 42.4-4.0		4.0	3.79	4.83	8.99	1.36	4.24	5.92	17.98	8.48	0.133	264.0	10.60
C 48.3-2.0	48.3	2.0	2.28	2.91	7.81	1.64	3.23	4.29	15.62	6.47	0.152	437.9	24.15
C 48.3-2.5		2.5	2.82	3.60	9.46	1.62	3.92	5.25	18.92	7.83	0.152	345.1	19.32
C 48.3-3.0		3.0	3.35	4.27	11.0	1.61	4.55	6.17	22.00	9.11	0.152	298.4	16.10
C 48.3-4.0		4.0	4.37	5.57	13.8	1.57	5.70	7.87	27.54	11.40	0.152	228.8	12.08
C 48.3-5.0		5.0	5.34	6.80	16.2	1.54	6.69	9.42	32.31	13.38	0.152	187.3	9.66
C 60.3-2.0	60.3	2.0	2.88	3.66	15.6	2.06	5.17	6.80	31.16	10.34	0.189	347.8	30.15
C 60.3-2.5		2.5	3.56	4.54	19.0	2.05	6.30	8.36	37.99	12.60	0.189	280.6	24.12
C 60.3-3.0		3.0	4.24	5.40	22.2	2.03	7.37	9.86	44.45	14.74	0.189	235.9	20.10
C 60.3-4.0		4.0	5.55	7.07	28.2	2.00	9.34	12.70	56.35	18.69	0.189	180.1	15.08
C 60.3-5.0		5.0	6.82	8.69	33.5	1.96	11.10	15.33	66.95	22.21	0.189	146.7	12.06

# COLD FORMED CIRCULAR HOLLOW SECTIONS

MS EN 10219 / BS EN 10219 / MANUFACTURER'S STANDARD

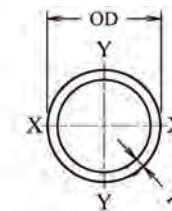

Tube Ref. No.(TRN)	Specified Dimension		Weight per unit length	Cross Sectional Area	Second Moment of Area	Radius of Gyration	Elastic Section Modulus	Plastic Section Modulus	Torsional Inertia Constant	Torsional Modulus Constant	Superficial area per meter length	Nominal length per tonne	Ratio for Local Buckling
	Outside Diameter	Thickness											D/T
	D	T	M	A	I	i	$W_{el}$	$W_{pl}$	$L_t$	$C_t$	$A_s$		
	mm	mm	kg/m	cm <sup>2</sup>	cm <sup>4</sup>	cm	cm <sup>3</sup>	cm <sup>3</sup>	cm <sup>4</sup>	cm <sup>3</sup>	m <sup>2</sup> /m	m	
C 76.1-2.0	76.1	2.0	3.65	4.66	32.0	2.62	8.40	10.98	63.96	16.81	0.239	273.6	38.05
C 76.1-2.5		2.5	4.54	5.78	39.2	2.60	10.30	13.55	78.37	20.60	0.239	220.4	30.44
C 76.1-3.0		3.0	5.41	6.89	46.1	2.59	12.11	16.04	92.19	24.23	0.239	184.9	25.37
C 76.1-4.0		4.0	7.11	9.06	59.1	2.55	15.52	20.81	118.11	31.04	0.239	140.6	19.03
C 76.1-5.0		5.0	8.77	11.17	70.9	2.52	18.64	25.32	141.84	37.28	0.239	114.1	15.22
C 76.1-6.0		6.0	10.37	13.21	81.8	2.49	21.49	29.56	163.52	42.97	0.239	96.4	12.68
C 76.1-6.3		6.3	10.84	13.81	84.8	2.48	22.29	30.78	169.64	44.58	0.239	92.2	12.08
C 88.9-2.0	88.9	2.0	4.29	5.46	51.6	3.07	11.60	15.11	103.14	23.20	0.279	233.3	44.45
C 88.9-2.5		2.5	5.33	6.79	63.4	3.06	14.26	18.67	126.75	28.51	0.279	187.7	35.56
C 88.9-3.0		3.0	6.36	8.10	74.8	3.04	16.82	22.15	149.53	33.64	0.279	157.3	29.63
C 88.9-4.0		4.0	8.38	10.67	96.3	3.00	21.67	28.85	192.68	43.35	0.279	119.4	22.23
C 88.9-5.0		5.0	10.35	13.18	116.4	2.97	26.18	35.24	232.75	52.36	0.279	96.7	17.78
C 88.9-6.0		6.0	12.27	15.63	134.9	2.94	30.36	41.31	269.88	60.72	0.279	81.5	14.82
C 88.9-6.3		6.3	12.83	16.35	140.2	2.93	31.55	43.07	280.47	63.10	0.279	77.9	14.11
C 101.6-2.5	101.6	2.5	6.11	7.78	95.6	3.50	18.82	24.56	191.22	37.64	0.319	163.7	40.64
C 101.6-3.0		3.0	7.29	9.29	113.0	3.49	22.25	29.17	226.07	44.50	0.319	121.4	33.87
C 101.6-4.0		4.0	9.63	12.26	146.3	3.45	28.80	38.12	292.57	57.59	0.319	103.9	25.40
C 101.6-5.0		5.0	11.91	15.17	177.5	3.42	34.93	46.70	354.94	69.87	0.319	84.0	20.32
C 101.6-6.0		6.0	14.15	18.02	206.7	3.39	40.68	54.91	413.35	81.37	0.319	70.7	16.93
C 101.6-6.3		6.3	14.81	18.86	215.1	3.38	42.34	57.30	430.13	84.67	0.319	67.5	16.13
C 114.3-2.5		114.3	2.5	6.89	8.78	137.3	3.95	24.02	31.25	274.52	48.03	0.359	145.1
C 114.3-3.0	3.0		8.23	10.49	162.5	3.94	28.44	37.17	325.10	56.88	0.359	121.4	38.10
C 114.3-4.0	4.0		10.88	13.86	211.1	3.90	36.93	48.69	422.13	73.86	0.359	91.9	28.58
C 114.3-5.0	5.0		13.48	17.17	256.9	3.87	44.96	59.77	513.84	89.91	0.359	74.2	22.86

# COLD FORMED CIRCULAR HOLLOW SECTIONS

MS EN 10219 / BS EN 10219 / MANUFACTURER'S STANDARD

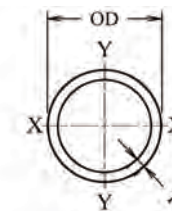

Tube Ref. No.(TRN)	Specified Dimension		Weight per unit length	Cross Sectional Area	Second Moment of Area	Radius of Gyration	Elastic Section Modulus	Plastic Section Modulus	Torsional Inertia Constant	Torsional Modulus Constant	Superficial area per meter length	Nominal length per tonne	Ratio for Local Buckling
	Outside Diameter	Thickness											D/T
	D	T	M	A	I	i	$W_{el}$	$W_{pl}$	$L_t$	$C_t$	$A_s$		
	mm	mm	kg/m	cm <sup>2</sup>	cm <sup>4</sup>	cm	cm <sup>3</sup>	cm <sup>3</sup>	cm <sup>4</sup>	cm <sup>3</sup>	m <sup>2</sup> /m	m	
C 114.3-6.0	114.3	6.0	16.03	20.41	300.2	3.83	52.53	70.45	600.42	105.06	0.359	62.4	19.05
C 114.3-6.3		6.3	16.78	21.38	312.7	3.82	54.72	73.57	625.43	109.44	0.359	59.6	18.14
C 114.3-8.0		8.0	20.97	26.72	379.5	3.77	66.40	90.57	758.98	132.81	0.359	47.7	14.29
C 139.7-3.0	139.7	3.0	10.11	12.88	301.1	4.83	43.11	56.07	602.18	86.21	0.439	98.9	46.57
C 139.7-4.0		4.0	13.39	17.05	392.9	4.80	56.24	73.68	785.72	112.49	0.439	74.7	34.93
C 139.7-5.0		5.0	16.61	21.16	480.5	4.77	68.80	90.76	961.08	137.59	0.439	60.2	27.94
C 139.7-6.0		6.0	19.78	25.20	564.3	4.73	80.78	107.33	1128.52	161.56	0.439	50.5	23.28
C 139.7-6.3		6.3	20.73	26.40	588.6	4.72	84.27	112.20	1177.24	168.54	0.439	48.2	22.17
C 139.7-8.0		8.0	26.00	33.10	720.3	4.66	103.12	138.93	1440.58	206.24	0.439	38.5	17.46
C 139.7-10.0		10.0	32.00	40.75	861.9	4.60	123.39	168.55	1723.79	246.78	0.439	31.3	13.97
C 168.3-4.0	168.3	4.0	16.21	20.65	697.1	5.81	82.84	108.00	1394.18	165.68	0.529	61.7	42.08
C 168.3-5.0		5.0	20.14	25.65	855.8	5.78	101.70	133.38	1711.69	203.41	0.529	49.7	33.66
C 168.3-6.0		6.0	24.02	30.59	1008.7	5.74	119.87	158.12	2017.39	239.74	0.529	41.6	28.05
C 168.3-6.3		6.3	25.17	32.06	1053.4	5.73	125.18	165.42	2106.84	250.37	0.529	39.7	26.71
C 168.3-8.0		8.0	31.63	40.29	1297.3	5.67	154.16	205.74	2594.54	308.32	0.529	31.6	21.04
C 168.3-10.0		10.0	39.04	49.73	1564.0	5.61	185.86	250.92	3127.97	371.71	0.529	25.6	16.83
C 177.8-4.0	177.8	4.0	17.14	21.84	825.1	6.15	92.81	120.85	1650.17	185.62	0.559	58.3	44.45
C 177.8-5.0		5.0	21.31	27.14	1014.0	6.11	114.06	149.34	2027.94	228.11	0.559	46.9	35.56
C 177.8-6.0		6.0	25.42	32.38	1196.2	6.08	134.56	177.16	2392.43	269.12	0.559	39.3	29.63
C 177.8-6.3		6.3	26.65	33.94	1249.6	6.07	140.56	185.38	2499.24	281.13	0.559	37.5	28.22
C 177.8-8.0		8.0	33.50	42.68	1541.4	6.01	173.39	230.83	3082.87	346.78	0.559	29.9	22.23
C 177.8-10.0		10.0	41.38	52.72	1862.0	5.94	209.45	281.90	3723.96	418.89	0.559	24.2	17.78



# COLD FORMED CIRCULAR HOLLOW SECTIONS

MS EN 10219 / BS EN 10219 / MANUFACTURER'S STANDARD

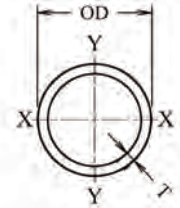

Tube Ref. No.(TRN)	Specified Dimension		Weight per unit length	Cross Sectional Area	Second Moment of Area	Radius of Gyration	Elastic Section Modulus	Plastic Section Modulus	Torsional Inertia Constant	Torsional Modulus Constant	Superficial area per meter length	Nominal length per tonne	Ratio for Local Buckling	
	Outside Diameter	Thickness											D/T	
	D	T	M	A	I	i	$W_{el}$	$W_{pl}$	$L_t$	$C_t$	$A_s$			
	mm	mm	kg/m	cm <sup>2</sup>	cm <sup>4</sup>	cm	cm <sup>3</sup>	cm <sup>3</sup>	cm <sup>4</sup>	cm <sup>3</sup>	m <sup>2</sup> /m	m		
C 193.7-4.0	193.7	4.0	18.71	23.84	1072.8	6.71	110.77	143.97	2145.58	221.54	0.609	53.4	48.43	
C 193.7-5.0		5.0	23.27	29.64	1320.2	6.67	136.32	178.08	2640.46	272.63	0.609		43.0	38.74
C 193.7-6.0		6.0	27.77	35.38	1559.7	6.64	161.05	211.46	3119.45	322.09	0.609		36.0	32.28
C 193.7-6.3		6.3	29.12	37.09	1630.0	6.63	168.31	221.33	3260.09	336.61	0.609		34.3	30.75
C 193.7-8.0		8.0	36.64	46.67	2015.5	6.57	208.11	276.05	4031.07	416.22	0.609		27.3	24.21
C 193.7-10.0		10.0	45.30	57.71	2441.6	6.50	252.10	337.79	4883.18	504.20	0.609		22.1	19.37
C 219.1-4.0	219.1	4.0	21.22	27.03	1563.8	7.61	142.75	185.09	3127.67	285.50	0.688	47.1	54.78	
C 219.1-5.0		5.0	26.40	33.63	1928.0	7.57	176.00	229.24	3856.09	351.99	0.688		37.9	43.82
C 219.1-6.0		6.0	31.53	40.17	2281.9	7.54	208.30	272.54	4563.89	416.60	0.688		31.7	36.52
C 219.1-6.3		6.3	33.06	42.12	2386.1	7.53	217.81	285.37	4772.28	435.63	0.688		30.2	34.78
C 219.1-8.0		8.0	41.65	53.06	2959.6	7.47	270.16	356.68	5919.27	540.33	0.688		24.0	27.39
C 219.1-10.0		10.0	51.57	65.69	3598.4	7.40	328.47	437.56	7196.88	656.95	0.688		19.4	21.91
C 273.0-6.0	273.0	6.0	39.51	50.33	4487.1	9.44	328.72	427.81	8974.17	657.45	0.858	25.3	45.50	
C 273.0-6.3		6.3	41.44	52.79	4695.8	9.43	344.02	448.20	9391.65	688.03	0.858		24.1	43.33
C 273.0-8.0		8.0	52.28	66.60	5851.7	9.37	428.70	561.97	11703.43	857.39	0.858		19.1	34.13
C 273.0-10.0		10.0	64.86	82.62	7154.1	9.31	524.11	692.02	14308.19	1048.22	0.858		15.4	27.30
C 323.9-6.0	323.9	6.0	47.04	59.92	7572.5	11.24	467.58	606.43	15144.93	935.16	1.018	21.3	53.98	
C 323.9-6.3		6.3	49.34	62.86	7928.9	11.23	489.59	635.56	15857.79	979.18	1.018		20.3	51.41
C 323.9-8.0		8.0	62.32	79.39	9910.1	11.17	611.92	798.51	19820.16	1223.84	1.018		16.0	40.49
C 323.9-10.0		10.0	77.41	98.61	12158.3	11.10	750.75	985.67	24316.68	1501.49	1.018		12.9	32.39
C 355.6-6.0	355.6	6.0	51.73	65.90	10070.6	12.36	566.40	733.39	20141.11	1132.80	1.117	19.3	59.27	
C 355.6-6.3		6.3	54.27	69.13	10547.2	12.35	593.21	768.75	21094.41	1186.41	1.117		18.4	56.44
C 355.6-8.0		8.0	68.58	87.36	13201.4	12.29	742.48	966.78	26402.75	1484.97	1.117		14.6	44.45
C 355.6-10.0		10.0	85.23	108.57	16223.5	12.22	912.46	1194.73	32447.00	1824.92	1.117		11.7	35.56

# CARBON STEEL TUBE FOR MACHINE STRUCTURAL PURPOSES AVAILABLE IN COLD ROLLED, HOT ROLLED AND ALUMINISED STEEL MATERIALS

JIS G 3445 STKM 11 A/MANUFACTURER'S STANDARD

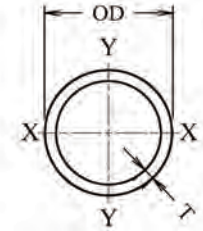

Tube Ref. No.(TRN)			NOMINAL SIZE	OUTER DIAMETER *		THICKNESS *												
						SWG	19				18				17			
HRC	HRC	HRC	mm	in	mm	MM	1.0				1.2				1.4			
1.0mm	1.2mm	1.4mm				IN	0.039				0.047				0.065			
							kg/m	kg/6m	kg/ft	lb/ft	kg/m	kg/6m	kg/ft	lb/ft	kg/m	kg/6m	kg/ft	lb/ft
C9.5-1.0			10	3/8	9.5		0.210	1.260	0.0639	0.141								
C12.7-1.0	C12.7-1.2	C12.7-1.4	12	1/2	12.7		0.289	1.734	0.088	0.194	0.340	2.040	0.104	0.229	0.390	2.340	0.119	0.262
C15.9-1.0	C15.9-1.2	C15.9-1.4	16	5/8	15.9		0.368	2.208	0.112	0.247	0.435	2.610	0.133	0.293	0.501	3.006	0.153	0.337
C19.1-1.0	C19.1-1.2	C19.1-1.4	19	3/4	19.1		0.447	2.682	0.136	0.300	0.530	3.180	0.162	0.357	0.611	3.666	0.186	0.410
C22.2-1.0	C22.2-1.2	C22.2-1.4	22	7/8	22.2		0.523	3.138	0.159	0.351	0.622	3.732	0.189	0.417	0.718	4.308	0.219	0.483
C25.4-1.0	C25.4-1.2	C25.4-1.4	25	1	25.4		0.602	3.612	0.183	0.404	0.716	4.296	0.218	0.481	0.829	4.974	0.253	0.588
C28.6-1.0	C28.6-1.2	C28.6-1.4	28	1 1/8	28.6		0.681	4.086	0.208	0.459	0.811	4.886	0.247	0.545	0.939	5.634	0.286	0.631
C31.8-1.0	C31.8-1.2	C31.8-1.4	32	1 1/4	31.8		0.760	4.560	0.232	0.512	0.906	5.436	0.276	0.609	1.050	6.300	0.320	0.706
	C34.9-1.2	C34.9-1.4	35	1 3/8	34.9						1.000	6.000	0.304	0.670	1.160	6.960	0.354	0.781
	C38.1-1.2	C38.1-1.4	38	1 1/2	38.1						1.092	6.552	0.333	0.734	1.267	7.602	0.386	0.851
	C41.3-1.2	C41.3-1.4	41	1 5/8	41.3						1.187	7.122	0.362	0.798	1.378	8.268	0.420	0.926
	C44.5-1.2	C44.5-1.4	44	1 3/4	44.5						1.281	7.686	0.391	0.862	1.488	8.928	0.454	1.001
	C47.6-1.2	C47.6-1.4	47	1 7/8	47.6						1.373	8.238	0.419	0.924	1.595	9.570	0.486	1.072
	C50.8-1.2	C50.8-1.4	50	2	50.8						1.468	8.808	0.447	0.986	1.705	10.230	0.520	1.146
	C54.0-1.2	C54.0-1.4	54	2 1/8	54						1.563	9.378	0.476	1.049	1.816	10.896	0.554	1.221
		C57.2-1.4	57	2 1/4	57.2										1.926	11.556	0.587	1.294
		C60.3-1.4	60	2 3/8	60.3										2.033	12.198	0.620	1.367
		C63.5-1.4	65	2 1/2	63.5										2.144	12.864	0.653	1.440

NOTE: \* Other diameters and/or thickness may be available by agreement with the manufacturer.

# CARBON STEEL TUBE FOR MACHINE STRUCTURAL PURPOSES AVAILABLE IN COLD ROLLED, HOT ROLLED AND ALUMINISED STEEL MATERIALS

JIS G 3445 STKM 11 A/MANUFACTURER'S STANDARD

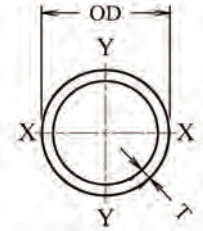

Tube Ref. No.(TRN)			NOMINAL SIZE	OUTER DIAMETER *		THICKNESS*												
						SWG	16				15				14			
HRC	HRC	HRC	mm	in	mm	MM	1.6				1.8				2.0			
1.6mm	1.8mm	2.0mm				IN	0.063				0.071				0.079			
							kg/m	kg/6m	kg/ft	lb/ft	kg/m	kg/6m	kg/ft	lb/ft	kg/m	kg/6m	kg/ft	lb/ft
C12.7-1.6	C12.7-1.8	C12.7-2.0	12	1/2	12.7		0.438	2.628	0.134	0.296	0.484	2.904	0.148	0.326	0.528	3.168	0.161	0.355
C15.9-1.6	C15.9-1.8	C15.9-2.0	16	5/8	15.9		0.564	3.384	0.172	0.379	0.626	3.756	0.191	0.421	0.686	4.116	0.209	0.461
C19.1-1.6	C19.1-1.8	C19.1-2.0	19	3/4	19.1		0.691	4.146	0.211	0.465	0.768	4.608	0.234	0.516	0.844	5.064	0.257	0.567
C22.2-1.6	C22.2-1.8	C22.2-2.0	22	7/8	22.2		0.813	4.878	0.248	0.547	0.906	5.436	0.276	0.609	0.996	5.976	0.304	0.670
C25.4-1.6	C25.4-1.8	C25.4-2.0	25	1	25.4		0.939	5.634	0.286	0.631	1.048	6.288	0.319	0.703	1.154	6.924	0.352	0.776
C28.6-1.6	C28.6-1.8	C28.6-2.0	28	1 1/8	28.6		1.066	6.396	0.325	0.717	1.190	7.140	0.363	0.800	1.312	7.872	0.400	0.882
C31.8-1.6	C31.8-1.8	C31.8-2.0	32	1 1/4	31.8		1.192	7.152	0.363	0.800	1.332	7.992	0.406	0.895	1.470	8.820	0.448	0.988
C34.9-1.6	C34.9-1.8	C34.9-2.0	35	1 3/8	34.9		1.318	7.908	0.402	0.886	1.469	8.814	0.448	0.988	1.623	9.738	0.495	1.091
C38.1-1.6	C38.1-1.8	C38.1-2.0	38	1 1/2	38.1		1.440	8.640	0.439	0.968	1.612	9.672	0.491	1.083	1.781	10.686	0.543	1.197
C41.3-1.6	C41.3-1.8	C41.3-2.0	41	1 5/8	41.3		1.567	9.402	0.478	1.054	1.754	10.524	0.534	1.177	1.938	11.628	0.591	1.303
C44.5-1.6	C44.5-1.8	C44.5-2.0	44	1 3/4	44.5		1.693	10.158	0.516	1.138	1.896	11.376	0.578	1.274	2.096	12.576	0.639	1.409
C47.6-1.6	C47.6-1.8	C47.6-2.0	47	1 7/8	47.6		1.815	10.890	0.553	1.219	2.033	12.198	0.620	1.367	2.249	13.494	0.686	1.512
C50.8-1.6	C50.8-1.8	C50.8-2.0	50	2	50.8		1.942	11.652	0.592	1.305	2.175	13.050	0.663	1.462	2.407	14.442	0.734	1.618
C54.0-1.6	C54.0-1.8	C54.0-2.0	54	2 1/8	54.0		2.068	12.408	0.630	1.389	2.317	13.902	0.706	1.557	2.565	15.390	0.782	1.724
C57.2-1.6	C57.2-1.8	C57.2-2.0	57	2 1/4	57.2		2.194	13.164	0.669	1.475	2.459	14.754	0.750	1.654	2.723	16.338	0.830	1.830
C60.3-1.6	C60.3-1.8	C60.3-2.0	60	2 3/8	60.3		2.316	13.896	0.706	1.557	2.597	15.582	0.792	1.746	2.876	17.256	0.877	1.934
C63.5-1.6	C63.5-1.8	C63.5-2.0	65	2 1/2	63.5		2.443	14.658	0.745	1.642	2.739	16.434	0.835	1.841	3.033	18.198	0.925	2.039

NOTE: \* Other diameters and/or thickness may be available by agreement with the manufacturer.

# LIPPED CHANNEL

JIS G 3350 /MANUFACTURER'S STANDARD

Tube Ref. No.(TRN)	Dimension mm (in)		Sectional Area	Calculated Weight	Centre of Gravity		Secondary Moment of Area		Radius of Gyration of Area		Modulus Section		Centre of Shear	
	H x A x C	t			cm <sup>2</sup>	kg/m	C <sub>x</sub>	C <sub>y</sub>	I <sub>x</sub>	I <sub>y</sub>	i <sub>x</sub>	i <sub>y</sub>	Z <sub>x</sub>	Z <sub>y</sub>
			cm	cm			cm <sup>4</sup>	cm <sup>4</sup>	cm	cm	cm <sup>3</sup>	cm <sup>3</sup>	cm	cm
LC250x75x25-4.5	250 x 75 x 25 (10 x 3 x 1)	4.5	18.92	14.90	0	2.07	1690.0	129.0	9.44	2.62	135.0	23.80	5.10	0
LC250x75x25-4.0		4.0	16.90	13.00	0	2.07	1518.0	120.0	9.48	2.66	121.4	22.00	5.20	0
LC250x75x25-3.2		3.2	13.96	10.96	0	2.07	1265.0	100.0	9.52	2.68	101.2	18.40	5.20	0
LC250x75x25-3.0		3.0	12.90	10.10	0	2.07	1177.0	94.0	9.54	2.69	94.1	17.30	5.20	0
LC250x75x20-4.5	250 x 75 x 20 (10 x 3 x ¾)	4.5	18.46	14.50	0	1.94	1638.0	116.0	9.41	2.51	131.0	21.00	4.94	0
LC250x75x20-4.0		4.0	16.51	12.96	0	1.95	1477.0	109.1	9.46	2.57	118.2	19.70	4.97	0
LC250x75x20-3.2		3.2	13.41	10.52	0	1.95	1210.0	89.2	9.5	2.58	96.8	16.10	4.99	0
LC250x75x20-3.0		3.0	12.60	9.89	0	1.95	1145.0	85.1	9.52	2.59	91.6	15.30	5.00	0
LC225x75x25-4.5	225 x 75 x 25 (9 x 3 x 1)	4.5	17.79	14.00	0	2.18	1310.0	125.0	8.57	2.64	116.0	23.50	5.33	0
LC225x75x25-4.0		4.0	15.92	12.50	0	2.19	1182.0	115.9	8.62	2.70	105.9	21.80	5.40	0
LC225x75x25-3.2		3.2	12.93	10.15	0	2.19	969.5	95.6	8.66	2.72	86.2	18.00	5.42	0
LC225x75x25-3.0		3.0	12.15	9.54	0	2.19	916.3	90.7	8.68	2.73	81.5	17.10	5.43	0
LC225x75x25-2.3		2.3	9.43	7.40	0	2.19	718.2	72.3	8.72	2.77	63.8	13.60	5.44	0
LC225x75x20-4.5	225 x 75 x 20 (9 x 3 x ¾)	4.5	17.34	13.60	0	2.05	1273.0	113.0	8.56	2.55	113.0	20.70	5.10	0
LC225x75x20-4.0		4.0	15.53	12.19	0	2.06	1151.0	105.8	8.61	2.61	102.3	19.50	5.12	0
LC225x75x20-3.2		3.2	12.61	9.90	0	2.06	943.3	86.5	8.65	2.62	8.4	15.90	5.13	0
LC225x75x20-3.0		3.0	11.85	9.30	0	2.06	892.0	82.6	8.67	2.63	79.3	15.20	5.13	0
LC225x75x20-2.3		2.3	9.20	7.21	0	2.06	699.6	66.0	8.72	2.67	62.2	12.10	5.14	0
LC200x75x25-4.5	200 x 75 x 25 (8 x 3 x 1)	4.5	16.67	13.10	0	2.32	990.0	121.0	7.71	2.69	99.0	23.30	5.60	0
LC200x75x25-4.0		4.0	14.95	11.70	0	2.32	895.0	110.0	7.74	2.72	89.5	21.30	5.70	0
LC200x75x25-3.2		3.2	12.10	9.52	0	2.33	736.0	92.3	7.79	2.76	73.6	17.80	5.70	0
LC200x75x25-3.0		3.0	11.41	8.96	0	2.33	694.0	88.2	7.8	2.78	69.4	17.10	5.80	0
LC200x75x20-4.5	200 x 75 x 20 (8 x 3 x ¾)	4.5	16.22	12.70	0	2.19	963.0	109.0	7.71	2.60	96.3	20.60	5.30	0
LC200x75x20-4.0		4.0	14.55	11.40	0	2.19	871.0	100.0	7.74	2.62	87.1	18.90	5.30	0
LC200x75x20-3.2		3.2	11.81	9.27	0	2.19	716.0	84.1	7.79	2.67	71.6	15.80	5.40	0
LC200x75x20-3.0		3.0	11.10	8.72	0	2.20	676.0	80.4	7.8	2.69	67.6	15.20	5.40	0



# LIPPED CHANNEL

JIS G 3350 / MANUFACTURER'S STANDARD

Tube Ref. No.(TRN)	Dimension mm (in)		Sectional Area	Calculated Weight	Centre of Gravity		Secondary Moment of Area		Radius of Gyration of Area		Modulus Section		Centre of Shear	
	H x A x C	t			cm <sup>2</sup>	kg/m	C <sub>x</sub>	C <sub>y</sub>	I <sub>x</sub>	I <sub>y</sub>	i <sub>x</sub>	i <sub>y</sub>	Z <sub>x</sub>	Z <sub>y</sub>
			cm	cm			cm <sup>4</sup>	cm <sup>4</sup>	cm	cm	cm <sup>3</sup>	cm <sup>3</sup>	cm	cm
LC175x75x20-4.5	175 x 75 x 20 ( 7 x 3 x ¾ )	4.5	15.09	11.80	0	2.33	702.0	104.0	6.81	2.62	80.2	20.10	5.63	0
LC175x75x20-4.0		4.0	13.55	10.60	0	2.33	636.0	95.9	6.85	2.66	72.7	18.60	5.65	0
LC175x75x20-3.2		3.2	11.00	8.64	0	2.34	521.0	79.6	6.88	2.69	59.5	15.40	5.66	0
LC175x75x20-3.0		3.0	10.35	8.13	0	2.34	495.0	76.3	6.91	2.71	56.6	14.80	5.67	0
LC175x75x20-2.3		2.3	8.05	6.31	0	2.34	389.0	61.0	6.95	2.75	44.5	11.80	5.68	0
LC150x65x20-4.5	150 x 65 x 20 ( 6 x 2½ x ¾ )	4.5	13.06	10.25	0	2.10	441.0	68.8	5.8	2.29	58.8	15.60	5.00	0
LC150x65x20-4.0		4.0	11.75	9.22	0	2.11	401.0	63.7	5.84	2.33	53.5	14.50	5.00	0
LC150x65x20-3.2		3.2	9.57	7.51	0	2.11	332.0	53.8	5.89	2.37	44.3	12.20	5.10	0
LC150x65x20-3.0		3.0	9.01	7.07	0	2.11	342.0	51.5	5.91	2.39	42.0	11.70	5.10	0
LC150x65x20-2.3		2.3	7.01	5.50	0	2.12	248.0	41.1	5.94	2.42	33.0	9.37	5.20	0
LC125x50x20-4.5	125 x 50 x 20 ( 5 x 2 x ¾ )	4.5	10.59	8.32	0	1.68	238.0	33.5	4.74	1.78	38.0	10.00	4.00	0
LC125x50x20-4.0		4.0	9.55	7.50	0	1.68	217.0	33.1	4.77	1.81	34.7	9.38	4.00	0
LC125x50x20-3.2		3.2	7.81	6.13	0	1.68	181.0	26.6	4.82	1.85	29.0	8.02	4.00	0
LC125x50x20-3.0		3.0	7.36	5.78	0	1.68	170.0	25.5	4.8	1.86	27.1	7.68	4.00	0
LC125x50x20-2.3		2.3	5.75	4.51	0	1.69	137.0	20.6	4.88	1.89	21.9	6.22	4.10	0
LC100x50x20-4.5	100 x 50 x 20 ( 4 x 2 x ¾ )	4.5	9.47	7.43	0	1.86	139.0	30.9	3.82	1.81	27.7	9.82	4.30	0
LC100x50x20-4.0		4.0	8.55	6.71	0	1.86	127.0	28.7	3.85	1.83	25.4	9.13	4.30	0
LC100x50x20-3.2		3.2	7.01	5.50	0	1.86	107.0	24.5	3.9	1.87	21.3	7.81	4.40	0
LC100x50x20-3.0		3.0	6.61	5.19	0	1.86	101.5	23.6	3.92	1.89	20.3	7.52	4.40	0
LC100x50x20-2.3		2.3	5.17	4.06	0	1.86	80.7	19.0	3.95	1.92	16.1	6.06	4.40	0

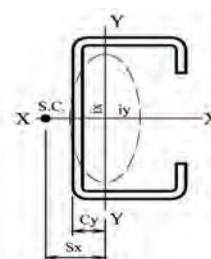
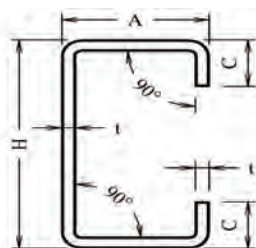

# PLAIN C-CHANNELS

JIS G 3350 /MANUFACTURER'S STANDARD

Tube Ref. No.(TRN)	Dimension mm (in)		Sectional Area	Calculated Weight	Centre of Gravity	Secondary Moment of Area		Radius of Gyration of Area		Modulus Section		Centre of Shear
	H x A	t			C <sub>y</sub>	I <sub>x</sub>	I <sub>y</sub>	i <sub>y</sub>	i <sub>y</sub>	Z <sub>x</sub>	Z <sub>y</sub>	S <sub>x</sub>
			cm	cm <sup>4</sup>	cm <sup>4</sup>	cm	cm	cm <sup>3</sup>	cm <sup>3</sup>	cm		
CC60x30-1.6	60 x 30	1.6	1.83	1.44	0.82	10.30	1.64	2.37	0.95	3.45	0.75	1.12
CC60x30-2.3		2.3	2.58	2.03	0.86	14.20	2.27	2.34	0.94	4.72	1.06	1.12
CC75x45-1.6	75 x 45	1.6	2.55	2.00	1.30	23.86	5.38	3.05	1.45	6.36	1.68	1.76
CC75x45-2.3		2.3	3.62	2.84	1.33	33.08	7.51	3.02	1.44	8.82	2.37	1.76
CC75x45-3.0		3.0	4.75	3.65	1.37	41.58	9.51	2.98	1.42	11.08	3.04	1.76
CC100x50-1.6	100 x 50	1.6	3.11	2.44	1.32	50.00	7.88	4.00	1.59	10.00	2.14	3.10
CC100x50-2.3		2.3	4.42	3.47	1.36	69.60	11.10	3.97	1.58	14.00	3.04	3.10
CC100x50-3.0		3.0	5.70	4.47	1.39	88.50	14.10	3.94	1.57	17.70	3.90	3.10
CC100x50-4.0		4.0	7.47	5.87	1.43	113.00	18.20	5.89	1.56	22.60	5.09	3.00
CC125x50-2.3	125 x 50	2.3	5.00	3.92	1.21	117.00	11.90	4.85	1.54	18.80	3.13	2.80
CC125x50-3.0		3.0	6.45	5.06	1.24	149.00	15.10	4.81	1.53	23.90	4.03	2.80
CC125x50-4.5		4.5	9.45	7.42	1.31	212.00	21.60	4.73	1.51	33.90	5.85	2.80
CC150x65-2.3	150 x 65	2.3	6.26	4.91	1.61	218.00	25.90	5.90	2.03	29.10	5.30	3.80
CC150x65-3.0		3.0	8.10	6.36	1.64	276.00	33.20	5.87	2.02	37.20	6.83	3.80
CC150x65-4.0		4.0	10.67	8.38	1.69	361.00	43.10	5.82	2.01	48.20	8.96	3.80
CC150x65-4.5		4.5	11.93	9.36	1.71	400.00	47.90	5.79	2.00	53.40	10.00	3.70
CC175x75-2.3	175 x 75	2.3	7.30	5.73	1.83	347.00	40.20	6.89	2.35	39.60	7.10	4.40
CC175x75-3.0		3.0	9.45	7.42	1.86	445.00	51.70	6.86	2.34	50.80	9.17	4.40
CC175x75-4.0		4.0	12.47	9.79	1.91	578.00	67.40	6.81	2.32	66.10	12.10	4.30
CC175x75-4.5		4.5	13.95	10.95	1.93	643.00	75.00	6.78	2.32	73.40	13.50	4.30
CC200x75-2.3	200 x 75	2.3	7.87	6.18	1.71	473.00	41.80	7.75	2.30	47.30	7.22	4.10
CC200x75-3.0		3.0	10.20	8.01	1.74	608.00	53.70	7.72	2.29	60.80	9.32	4.10
CC200x75-4.0		4.0	13.47	10.58	1.78	792.00	70.10	7.67	2.28	79.20	12.30	4.10
CC200x75-4.5		4.5	15.08	15.08	1.80	881.00	78.00	7.64	2.27	88.10	13.70	4.10

NOTE: Sizes with shaded are uncommon size

# PLAIN C-CHANNELS

JIS G 3350 / MANUFACTURER'S STANDARD

Tube Ref. No.(TRN)	Dimension mm (in)		Sectional Area	Calculated Weight	Centre of Gravity	Secondary Moment of Area		Radius of Gyration of Area		Modulus Section		Centre of Shear
	H x A	t			$C_y$	$I_x$	$I_y$	$i_y$	$i_y$	$Z_x$	$Z_y$	$S_x$
			cm <sup>2</sup>	kg/m	cm	cm <sup>4</sup>	cm <sup>4</sup>	cm	cm	cm <sup>3</sup>	cm <sup>3</sup>	cm
CC225x75-2.3	225 x 75	2.3	8.45	6.63	1.60	624.00	43.20	8.60	2.23	55.50	13.90	3.90
CC225x75-3.0		3.0	10.95	8.59	1.63	803.00	55.50	8.56	2.24	71.30	12.40	3.90
CC225x75-4.0		4.0	14.47	11.36	1.67	1048.00	72.40	8.51	2.25	93.00	9.45	3.90
CC225x75-4.5		4.5	16.20	12.72	1.70	1166.00	80.60	8.48	2.26	104.00	7.31	3.90
CC250x75-2.3	250 x 75	2.3	9.02	7.08	1.60	802.00	44.30	9.43	2.22	64.20	7.40	3.80
CC250x75-3.0		3.0	11.70	9.18	1.58	1032.00	57.00	9.39	2.21	82.50	9.56	3.70
CC250x75-4.0		4.0	15.47	12.15	1.54	1348.00	74.50	9.33	2.19	108.00	12.60	3.70
CC250x75-4.5		4.5	17.33	13.60	1.50	1502.00	82.90	9.31	2.19	120.00	14.10	3.70

NOTE: Sizes with shaded are uncommon size

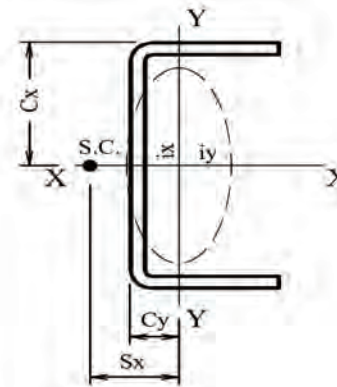
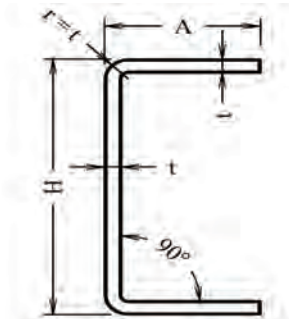

## SPECIAL SIZES

### GATE CHANNEL

MANUFACTURER'S STANDARD

Tube Ref. No.(TRN)	Dimension (B x A x B)	Thickness mm	Calculated weight	
	mm		kg/m	kg/6m
GC19x10-2.3	10 x 19 x 10	2.3	0.58	3.48

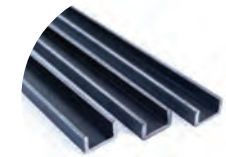

### U-CHANNEL

MANUFACTURER'S STANDARD

Tube Ref. No.(TRN)	Dimension (A x B)	Thickness mm	Calculated weight	
	mm		kg/m	kg/6m
UC25x25-1.5	25 x 25	1.5	0.83	4.98
UC30x30-1.5	30 x 30	1.5	1.00	6.00

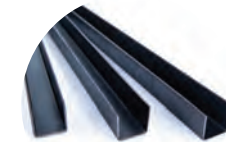

### TROLLEY TRACK

MANUFACTURER'S STANDARD

Tube Ref. No.(TRN)	Dimension (A x B x C)	Thickness mm	Calculated weight	
	mm		kg/m	kg/6m
TT50x50x15-1.5	50 x 50 x 15	1.5	2.00	12.00
TT50x50x15-2.3		2.3	2.98	17.88
TT50x50x15-3.0		3.0	3.77	22.62

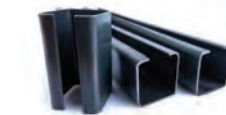
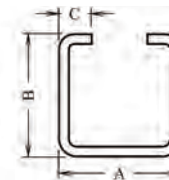

### DOOR RAIL TRACK

MANUFACTURER'S STANDARD

Tube Ref. No.(TRN)	Dimension (A x B x C)	Thickness mm	Calculated weight	
	mm		kg/m	kg/6m
DR44x65x15-1.6	44 x 65 x 15	1.5	2.04	12.24
DR44x65x15-2.3		2.3	3.21	19.26

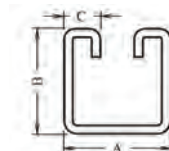



# SPECIAL SIZES

## OBLONG TUBES

MANUFACTURER'S STANDARD

Tube Ref. No.(TRN)	Dimension (A x B)	Thickness mm	Calculated weight	
	mm		kg/m	kg/6m
OT19x10-1.1	19 x 10	1.10	0.40	2.40
OT19x11-0.7	19 x 11	0.70	0.28	1.68
OT24x12-1.1	24 x 12	1.10	0.48	2.88
OT32x16-2.0	32 x 16	2.00	1.13	6.78
OT46x20-2.3	46 x 20	2.30	1.89	11.34
OT50x25-2.0	50 x 25	2.00	1.86	11.16
OT50x25-2.3		2.30	2.15	12.90
OT59x30-1.6	59 x 30	1.60	1.80	10.80

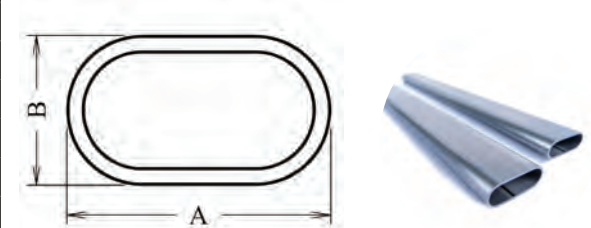

## D - TUBE

MANUFACTURER'S STANDARD

Tube Ref. No.(TRN)	Dimension (A x B)	Thickness mm	Calculated weight	
	mm		kg/m	kg/6m
DT50x25-1.2	50 x 25	1.20	1.20	7.20



NOTE: Sizes with shaded are uncommon size

# HOT DIP GALVANISING SERVICES

BS EN ISO 1461 : 2009 Hot dip galvanized coating on fabricated iron and steel articles

Table 1 – Coating minimum masses (related to thicknesses) on samples that are not centrifuged

Article and its thickness	Local coating (minimum) <sup>b</sup>	Local coating (minimum) <sup>a</sup>	Mean coating (minimum) <sup>b</sup>	Mean coating (minimum) <sup>c</sup>
	mass, g/m <sup>2</sup>	thickness, µm	mass, g/m <sup>2</sup>	thickness, µm
Steel > 6 mm	505	70	610	85
Steel > 3 mm to ≤ 6 mm	395	55	505	70
Steel ≥ 1.5 mm to ≤ 3 mm	325	45	395	55
Steel < 1.5 mm	250	35	325	45
Castings ≥ 6 mm	505	70	575	80
Castings < 6 mm	430	60	505	70

- a mean value of coating thickness obtained from the specific number of measurement within a reference area for a magnetic test or the single value from a gravimetric area
- b Equivalent coating mass using a nominal coating density of 7,2 g/cm<sup>3</sup>
- c average value of the local thickness

Table 2 – Coating minimum masses (related to thicknesses) on samples that are centrifuged

Article and its thickness	Local coating (minimum) <sup>b</sup>	Local coating (minimum) <sup>a</sup>	Mean coating (minimum) <sup>b</sup>	Mean coating (minimum) <sup>c</sup>
	mass, g/m <sup>2</sup>	thickness, µm	mass, g/m <sup>2</sup>	thickness, µm
Articles with threads:				
>6 mm diameter	285	40	360	50
≤6 mm diameter	145	20	180	25
Other articles (including castings) :				
≥ 3 mm	325	45	395	55
< 3mm	250	35	325	45

- a mean value of coating thickness obtained from the specific number of measurement within a reference area for a magnetic test or the single value from a gravimetric area
- b Equivalent coating mass using a nominal coating density of 7,2 g/cm<sup>3</sup>
- c average value of the local thickness

# CONVERSION TABLE OF ZINC COATING

Coating weight		Thickness	
oz/ft <sup>2</sup>	g/m <sup>2</sup>	mil 1/1000 (in)	μ 1/1000 (mm)
0.40	122.0	0.67	17.0
0.42	128.1	0.70	17.9
0.44	134.2	0.74	18.7
0.46	140.3	0.77	19.6
0.48	146.3	0.81	20.4
0.50	152.5	0.84	21.3
0.52	158.6	0.87	22.2
0.54	164.7	0.91	23.0
0.56	170.8	0.94	23.9
0.58	176.9	0.97	24.7
0.60	183.0	1.01	25.6
0.62	189.1	1.04	26.4
0.64	195.2	1.07	27.3
0.66	201.3	1.11	28.1
0.68	207.4	1.14	29.0
0.70	213.5	1.17	29.8
0.72	219.6	1.21	30.7
0.74	225.7	1.24	31.5
0.76	231.8	1.27	32.4
0.78	237.9	1.31	33.2
0.80	244.0	1.34	34.1
0.82	250.1	1.38	34.9
0.84	256.2	1.41	35.8
0.86	262.3	1.44	36.6
0.88	268.4	1.48	37.5
0.90	274.5	1.51	38.3
0.92	280.6	1.54	39.2

Coating weight		Thickness	
oz/ft <sup>2</sup>	g/m <sup>2</sup>	mil 1/1000 (in)	μ 1/1000 (mm)
0.94	286.7	1.58	40.0
0.96	292.8	1.61	40.9
0.98	298.9	1.64	41.7
1.00	305.0	1.68	42.6
1.02	311.1	1.71	43.4
1.04	317.2	1.74	44.3
1.06	323.3	1.78	45.2
1.08	329.4	1.81	46.0
1.10	335.5	1.84	46.9
1.12	341.6	1.88	47.7
1.14	347.7	1.91	48.6
1.16	353.8	1.95	49.4
1.18	359.9	1.98	50.3
1.20	366.0	2.01	51.1
1.22	372.1	2.05	52.0
1.24	378.2	2.08	52.8
1.26	384.3	2.11	53.7
1.28	390.4	2.15	54.5
1.30	396.5	2.18	55.4
1.32	402.6	2.21	56.2
1.34	408.7	2.25	57.1
1.36	414.8	2.28	57.9
1.38	420.9	2.31	58.8
1.40	427.0	2.35	59.6
1.42	433.1	2.38	60.5
1.44	439.2	2.41	61.3
1.46	445.3	2.45	62.2

# CONVERSION TABLE OF ZINC COATING

Coating weight		Thickness	
oz/ft <sup>2</sup>	g/m <sup>2</sup>	mil 1/1000 (in)	μ 1/1000 (mm)
1.48	451.4	2.48	63.0
1.50	457.5	2.52	63.9
1.52	463.6	2.55	64.7
1.54	469.7	2.58	65.6
1.56	475.8	2.62	66.4
1.58	481.9	2.65	67.3
1.60	488.0	2.68	68.2
1.62	494.1	2.72	69.0
1.64	500.2	2.75	69.9
1.66	506.3	2.78	70.7
1.68	512.4	2.82	71.6
1.70	518.5	2.85	72.4
1.72	524.6	2.88	73.3
1.74	530.7	2.92	74.1
1.76	536.8	2.95	75.0
1.78	542.9	2.99	75.8
1.80	549.0	3.02	76.7
1.82	555.1	3.05	77.5
1.84	561.2	3.09	78.4
1.86	567.3	3.12	79.2
1.88	573.4	3.15	80.1
1.90	579.5	3.19	80.9
1.92	585.6	3.22	81.8
1.94	591.7	3.25	82.6
1.96	597.8	3.29	83.5
1.98	603.9	3.32	84.3
2.00	610.0	3.35	85.2

Coating weight		Thickness	
oz/ft <sup>2</sup>	g/m <sup>2</sup>	mil 1/1000 (in)	μ 1/1000 (mm)
2.02	616.1	3.39	86.0
2.04	622.2	3.42	86.9
2.06	628.3	3.45	87.7
2.08	634.4	3.49	88.6
2.10	640.5	3.52	89.4
2.12	646.6	3.55	90.3
2.14	652.7	3.59	91.1
2.16	658.8	3.62	92.0
2.18	664.9	3.66	92.9
2.20	671.0	3.69	93.7
2.22	677.1	3.72	94.6
2.24	683.2	3.76	95.4
2.26	689.3	3.79	96.3
2.28	695.4	3.82	97.1
2.30	701.5	3.86	98.0
2.32	707.6	3.89	98.8
2.34	713.7	3.92	99.7
2.36	719.8	3.96	100.5
2.38	725.9	3.99	101.4
2.40	732.0	4.02	102.2
2.42	738.1	4.06	103.1
2.44	744.2	4.09	103.9
2.46	750.3	4.12	104.8
2.48	756.4	4.16	105.6
2.50	762.5	4.19	106.5
2.52	768.6	4.23	107.3
2.54	774.7	4.26	108.2



# CONVERSION TABLE OF ZINC COATING

Coating weight		Thickness	
oz/ft <sup>2</sup>	g/m <sup>2</sup>	mil 1/1000 (in)	μ 1/1000 (mm)
2.56	780.8	4.29	109.0
2.58	786.9	4.33	109.9
2.60	793.0	4.36	110.7
2.62	799.1	4.39	111.6
2.64	805.2	4.43	112.3
2.66	811.3	4.46	113.4
2.68	817.4	4.49	114.1
2.70	823.5	4.53	115.0
2.72	829.6	4.56	115.8
2.74	835.7	4.59	116.7
2.76	841.8	4.63	117.5
2.78	847.9	4.66	118.4
2.80	854.0	4.69	119.2
2.82	860.1	4.73	120.1
2.84	866.2	4.76	120.9
2.86	872.3	4.79	121.8
2.88	878.4	4.83	122.6
2.90	884.5	4.86	123.5
2.92	890.6	4.89	124.3
2.94	896.7	4.93	125.2
2.96	902.8	4.96	126.0
2.98	908.9	4.99	126.9
3.00	915.0	5.03	127.7
3.02	921.1	5.06	128.6
3.04	927.2	5.09	129.4
3.06	933.3	5.13	130.3
3.08	939.4	5.16	131.1

Coating weight		Thickness	
oz/ft <sup>2</sup>	g/m <sup>2</sup>	mil 1/1000 (in)	μ 1/1000 (mm)
3.10	945.5	5.20	132.0
3.12	951.6	5.23	132.8
3.14	957.7	5.26	133.7
3.16	963.8	5.30	134.5
3.18	969.9	5.33	135.4
3.20	976.0	5.36	136.2
3.22	982.1	5.40	137.1
3.24	988.2	5.43	137.9
3.26	994.3	5.46	138.8
3.28	1000.4	5.50	139.6
3.30	1006.5	5.53	140.5
3.32	1012.6	5.56	141.3
3.34	1018.7	5.60	142.2
3.36	1024.8	5.63	143.0
3.38	1030.9	5.66	143.9
3.40	1037.0	5.70	144.7
3.42	1043.1	5.73	145.6
3.44	1049.2	5.76	146.4
3.46	1055.3	5.80	147.3
3.48	1061.4	5.83	148.1
3.50	1067.5	5.86	149.0
3.52	1073.6	5.90	149.8
3.54	1079.7	5.93	150.7
3.56	1085.8	5.97	151.5
3.58	1091.9	6.00	152.4
3.60	1098.0	6.03	153.2





*Storage Bay, Factory 1*



*Factory 3*

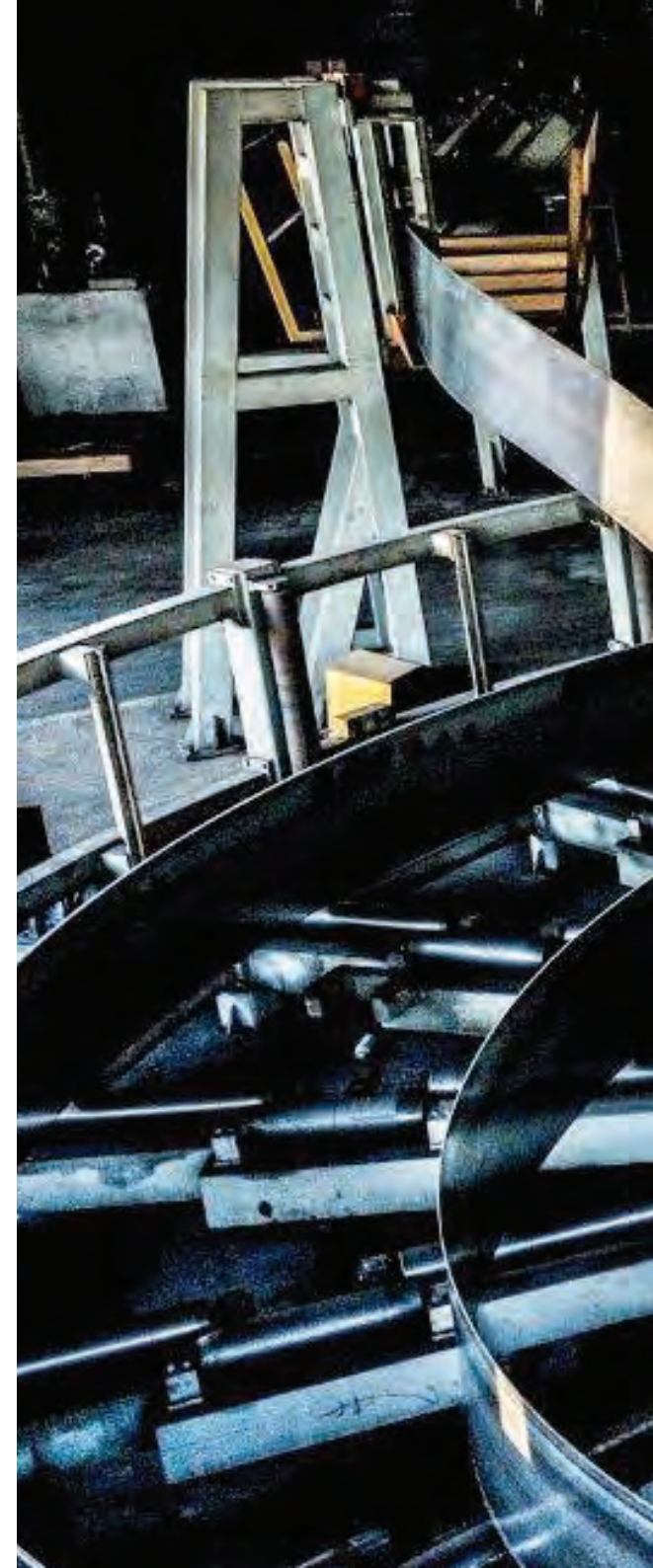



*The Largest Accumulator*

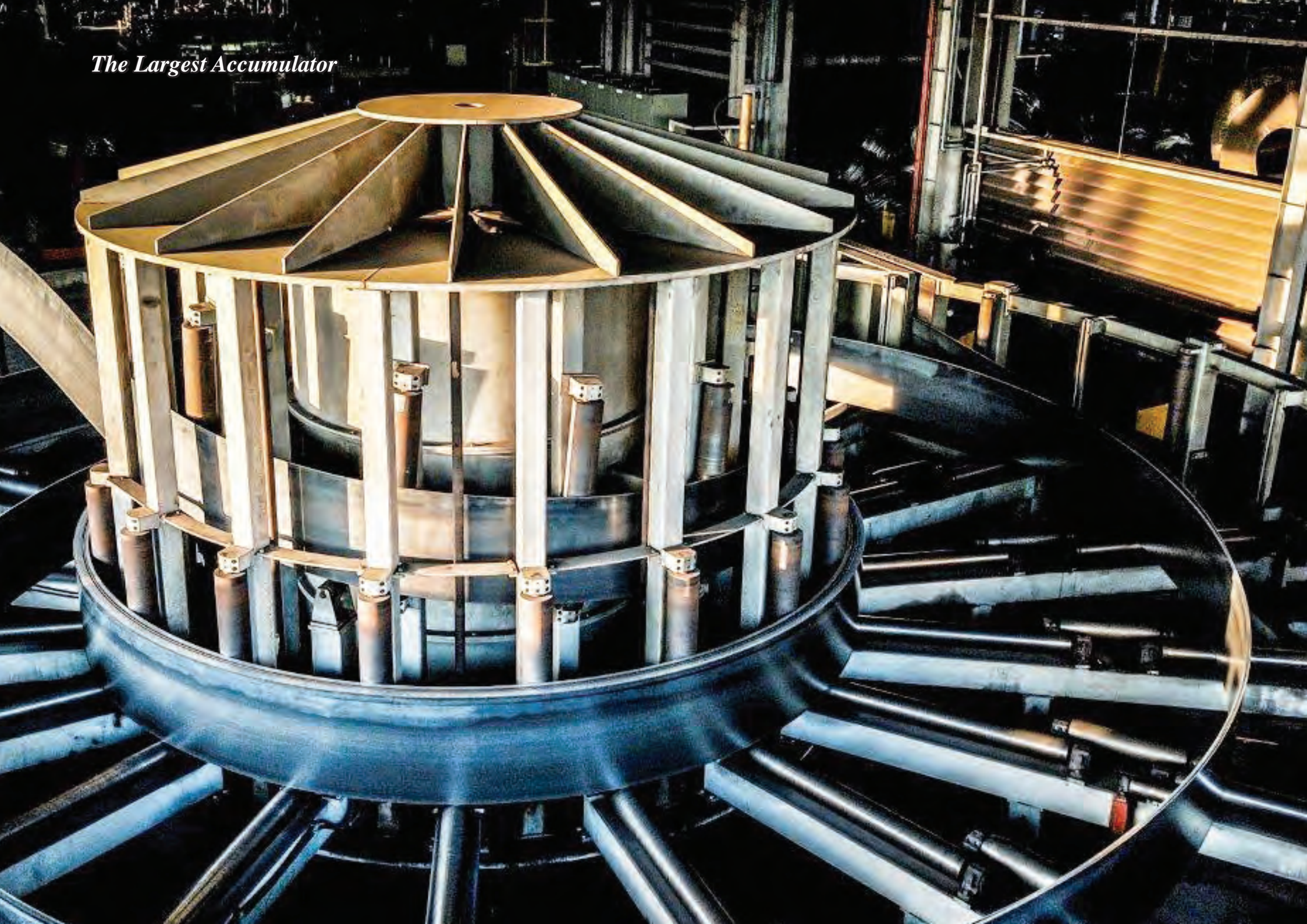



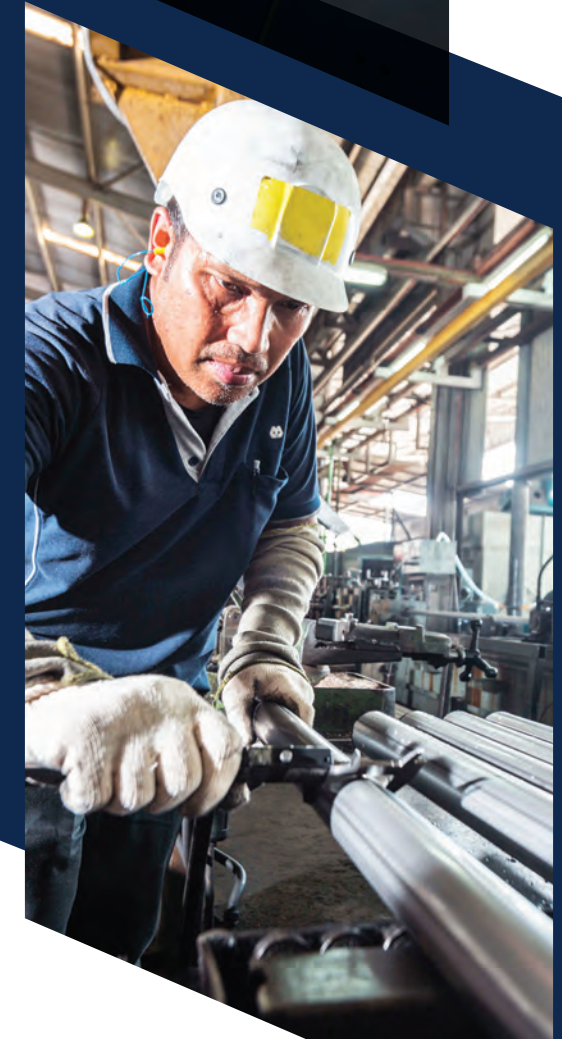
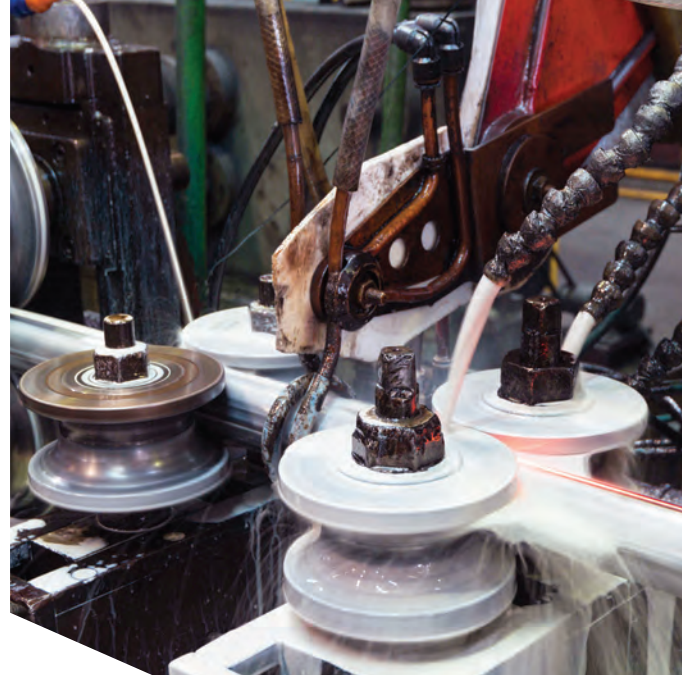

**MELEWAR STEEL TUBE SDN. BHD.** (111059-D)

Lot 53 Persiaran Selangor,  
40200 Shah Alam,  
Selangor Darul Ehsan, Malaysia

Tel : 603-5519 2455 (12 lines)  
Fax : 603-5519 2033 (Administration)  
603-5510 6410, 603-5519 4017 (Sales Dept)  
Email (Admin) : [enquiry@melewar-mig.com](mailto:enquiry@melewar-mig.com)  
(Sales) : [sales@melewar-mig.com](mailto:sales@melewar-mig.com)  
GPS location : N03°04.276'E101°32.843'